

STERN 16B-3 TRANSFORMER WIRING CONNECTION INSTRUCTIONS

115/120V., 50/60 Cycle Input.
Varistor - Soldered to Line Filter on Left Side of Cabinet
Must Be Stern Part No. 25A-18-1.

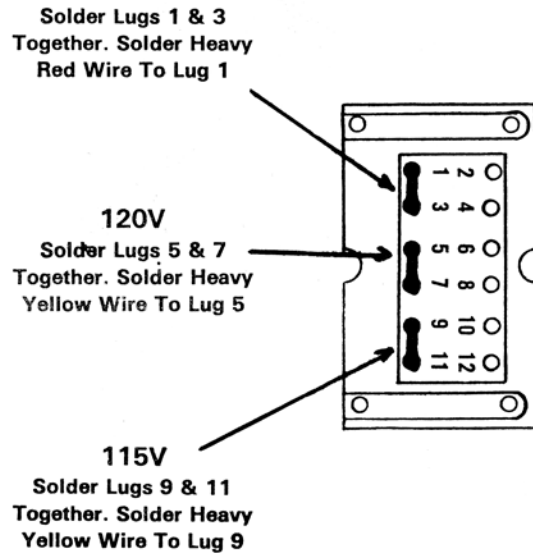

220/240V., 50/60 Cycle Input.
Varistor - Soldered to Line Filter on Left Side of Cabinet
Must be Stern Part No. 25A-18-2.

