

The Getaway (50004)

FUSE LIST

POWER DRIVER BOARD		
F101	+50V DC General (Left Flipper)	3A, 250V, SB Not Used
F102	+50V DC General (Right Flipper)	3A, 250V, SB Not Used
F103	Solenoids #25 to #28	3A, 250V, SB
F104	Solenoids #9 to #16	3A, 250V, SB
F105	Solenoids #1 to #8	3A, 250V, SB
F106	G.I. #5 White-Violet	5A, 250V, SB
F107	G.I. #4 White-Green	5A, 250V, SB
F108	G.I. #3 White-Yellow	5A, 250V, SB
F109	G.I. #2 White-Orange	5A, 250V, SB
F110	G.I. #1 White-Brown	5A, 250V, SB
F111	Flasher Secondary	5A, 250V, SB
F112	Solenoid Secondary	7A, 250V, SB
F113	+5V Logic	5A, 250V, SB
F114	+18V Lamp Matrix	8A, 32V, N.B.
F115	+12V Switch Matrix	3/4A, 250V, FB
F116	+12V Secondary	3A, 250V, SB
Audio Board		
F501	-25V Circuit	3A, 250V, SB
F502	+25V Circuit	3A, 250V, SB
Dot Matrix Controller Board		
F601	+62V Circuit	3/8A, 250V, FB
F602	-113V & -125V Circuits	3/8A, 250V, FB
LINE FILTER		
Foreign		5A, 250V, SB
Domestic		8A, 250V, SB

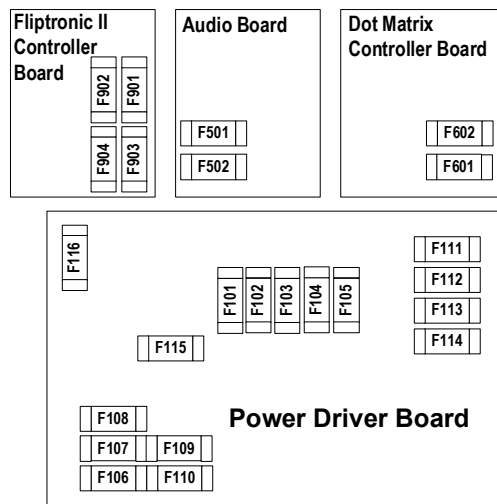

Fliptronic II Controller Board		
F901	Upper Right Flipper	3A, 250V, SB
F902	Upper Left Flipper	3A, 250V, SB
F903	Lower Right Flipper	3A, 250V, SB
F904	Lower Left Flipper	3A, 250V, SB

SOLENOID/FLASHER TABLE

Sol No.	Function	Solenoid Type	Voltage Connections			Drive Xistor	Drive Connections			Drive Wire Color	Solenoid Part Number Flashlamp Type	
			Playfield	Backbox	Cabinet		Playfield	Insert	Cabinet		Playfield	Insert
01	Diverter High	High Power	J107-3			Q82	J130-1			VIO-BRN	A-14701	
02	Up Ramp	High Power	J107-3			Q80	J130-2			VIO-RED	AE-26-1200	
03	Down Ramp	High Power	J107-3			Q78	J130-4			VIO-ORG	SM1-28-900-DC	
04	Locker (Disappearing Post)	High Power	J107-3			Q76	J130-5			VIO-YEL	AE-26-1200	
05	Left Slingshot	High Power	J107-3			Q64	J130-6			VIO-GRN	AE-26-1500	
06	Right Slingshot	High Power	J107-3			Q66	J130-7			VIO-BLU	AE-26-1500	
07	Knocker	High Power		J107-3		Q68	J130-8			VIO-BLK	AE-23-800	
08	Kickback	High Power	J107-3			Q70	J130-9			VIO-GRY	AE-23-800	
09	Eject Hole	Low Power	J107-2			Q58	J127-1			BRN-BLK	AE-26-1200	
10	Diverter Low	Low Power	J107-3			Q56	J127-3			BRN-RED	A-14701	
11	Ball Release (Trough)	Low Power	J107-2			Q54	J127-4			BRN-ORG	AE-27-1200	
12	Plunger Kicker	Low Power	J107-2			Q52	J127-5			BRN-YEL	A-14789	
13	Top Jet Bumper	Low Power	J107-2			Q50	J127-6			BRN-GRN	AE-26-1200	
14	Left Jet Bumper	Low Power	J107-2			Q48	J127-7			BRN-BLU	AE-26-1200	
15	Bottom Jet Bumper	Low Power	J107-2			Q46	J127-8			BRN-VIO	AE-26-1200	
16	Outhole	Low Power	J107-2			Q44	J127-9			BRN-GRY	AE-26-1200	
17	Right Bank Flasher	Flasher	J107-6			Q42	J126-1			BLK-BRN	#89	#906
18	Supercharger Flasher	Flasher	J107-6			Q40	J126-2	J125-2		BLK-RED		#906
19	Left Slingshot Flasher	Flasher	J107-6			Q38	J126-3	J125-3		BLK-ORG	#89	#906
20	Free Ride Flasher	Flasher	J107-6			Q36	J126-4			BLK-YEL		#906
21	Left Ramp Flasher	Flasher	J107-6			Q28	J126-5	J125-6		BLU-GRN	#89	#906
22	Left Bank Flasher	Flasher	J107-6			Q30	J126-6			BLU-BLK	#89	-
23	Flipper Flasher	Flasher	J107-6			Q34	J126-7	J125-8		BLU-VIO	#89	#906
24	Right Slingshot Flasher	Flasher	J107-6			Q32	J126-8	J125-9		BLU-GRY	#89	#906
25	Enable 1	Low Power	J107-1			Q26	J122-1			BLU-BRN	A-15685	
26	Enable 2	Low Power	J107-1			Q24	J122-2			BLU-RED	A-15685	
27	Revolving Lamp	Low Power			J106-5	Q22			J123-4	BLU-ORG	14-7971	
28	Enable 3	Low Power	J107-1			Q20	J122-4			BLU-YEL	A-15685	
General Illumination		Voltage Connections			Drive Xistor	Drive Connections			Drive Wire	Bulb Type		
		Playfield	Backbox	Cabinet		Playfield	Backbox	Cabinet		Playfield	Backbox	
01	Playfield G.I.	G.I.	J120-1			Q18	J120-7			WHT-BRN	#555	#555
02	Playfield G.I.	G.I.	J120-2			Q10	J120-8			WHT-ORG	#555	#555
03	Insert G.I.	G.I.	J120-3	J121-3		Q14		J121-9		WHT-YEL	#555	#555
04	Insert G.I.	G.I.		J121-5		Q16		J121-10		WHT-GRN	#555	#555
05	Insert G.I.	G.I.		J121-6	J119-3	Q12		J121-11	J119-1	WHT-VIO	#555	#555
Flipper Circuits		Playfield Voltage Connection		Drive Transistors Power Hold		Playfield Drive Connections		Drive Wire Colors Power Hold		Coil Part No.	Coil Colors	
	LOWER LEFT FLIPPER	Flipper	J907-6, 7 (GRY-YEL)	Q3	Q9	J902-7, 9		BLU-GRY ORG-BLU	FL-15629		BLUE	
	LOWER RIGHT FLIPPER	Flipper	J907-8, 9 (BLU-YEL)	Q4	Q11	J902-11, 13		BLU-VIO ORG-GRN	FL-15629		BLUE	
	UPPER RIGHT FLIPPER	Flipper	J907-4, 5 (BLU-YEL)	Q2	Q7	J902-4, 6		BLK-BLU ORG-VOI	FL-11630		RED	

LAMP MATRIX

Column	Red ← Yellow (B+) →							
	1 Yellow-Brown J137-1 Q98	2 Yellow-Red J137-2 Q97	3 Yellow-Orange J137-3 Q96	4 Yellow-Black J137-4 Q95	5 Yellow-Green J137-5 Q94	6 Yellow-Blue J137-6 Q93	7 Yellow-Violet J137-7 Q92	8 Yellow-Gray J137-8 Q91
1 Red-Brown J133-1 Q90	FREEWAY 1	2X	TOP RED	TACH 1	SHOOT AGAIN	RIGHT RETURN LANE	4 TH GEAR	TACH 9
2 Red-Black J133-2 Q89	FREEWAY 2	4X	TOP YELLOW	TACH 2	KICKBACK	LEFT RETURN LANE	5 TH GEAR	TACH 10
3 Red-Orange J133-4 Q88	FREEWAY 3	HOLD BONUS	TOP GREEN	TACH 3	TACH 11	SIX BANK BOTTOM	STOP LIGHT RED	MIDDLE RED
4 Red-Yellow J133-5 Q87	FREEWAY 4	6X	RIGHT FREEWAY	TACH 4	TACH 12	SIX BANK MIDDLE	STOP LIGHT YELLOW	MIDDLE YELLOW
5 Red-Green J133-6 Q86	FREEWAY 5	8X	SPECIAL	TACH 5	TACH 13	SIX BANK TOP	STOP LIGHT GREEN	MIDDLE GREEN
6 Red-Blue J133-7 Q85	SPEED	GET AWAY	VIDEO MODE	BOTTOM RED	TACH 14	SUPER CHARGER	1 ST GEAR	TACH 6
7 Red-Violet J133-8 Q84	LEFT FREEWAY	SPEED MILLIONS	RANDOM LAMP	BOTTOM YELLOW	TACH 15	RED LINE MANIA	2 ND GEAR	TACH 7
8 Red-Grey J133-9 Q83	LOCK	SUPER JACKPOT	EXTRA BALL	BOTTOM GREEN	SHIFT	START BUTTON	3 RD GEAR	TACH 8

J1XX = Power Driver Board

SWITCH MATRIX

DEDICATED GROUNDED SWITCHES	Column	White → Green								FLIPPER GROUNDED SWITCHES
		1 Green-Brown J207-1 U20-18	2 Green-Red J207-2 U20-17	3 Green-Orange J207-3 U20-16	4 Green-Yellow J207-4 U20-15	5 Green-Black J207-5 U20-14	6 Green-Blue J207-6 U20-13	7 Green-Violet J207-7 U20-12	8 Green-Grey J207-9 U20-11	
Orange-Brown J205-1 LEFT COIN CHUTE U17-5	1 White-Brown J209-1 U18-11	NOT USED	SLAM TILT	LEFT SLING	TOP YELLOW	TOP GREEN	TOP JET	TOP LOOP	OPTO 1	BLACK-GREEN J906-1 LOWER RIGHT E.O.S. SWITCH
Orange-Red J205-2 CENTER COIN CHUTE U17-7	2 White-Red J209-2 U18-9	NOT USED	COIN DOOR CLOSED	RIGHT SLING	MIDDLE YELLOW	MIDDLE GREEN	LEFT JET	MIDDLE LOOP	OPTO 2	BLUE-VIOLET J905-1 LOWER RIGHT FLIPPER BUTTON
Orange-Black J205-3 RIGHT COIN CHUTE U17-11	3 White-Orange J209-3 U18-5	START BUTTON	TICKET OPTO.	GEAR SHIFTER LOW	BOTTOM YELLOW	BOTTOM GREEN	BOTTOM JET	BOTTOM LOOP	OPTO 3	BLACK-BLUE J906-3 LOWER LEFT E.O.S. SWITCH
Orange-Yellow J205-4 4 TH COIN CHUTE U17-9	4 White-Yellow J209-4 U18-7	PLUMB BOB TILT	ALWAYS CLOSED	GEAR SHIFTER HIGH	RIGHT BANK BOTTOM	RAMP DOWN	NOT USED	TOP LOCK	OPTO MADE LOOP	BLUE-GRAY J905-2 LOWER LEFT FLIPPER BUTTON
Orange-Green J205-6 Normal Function Srv Crdts	5 White-Green J209-5 U19-11	LEFT FREEWAY BOTTOM	LEFT OUTLANE	NOT USED	RIGHT BANK MIDDLE	OUTHOLE	MADE UP/DOWN RAMP	MIDDLE LOCK	ENTER LEFT RAMP	BLACK-VIOLET J906-4 UPPER RIGHT E.O.S. SWITCH
Orange-Blue J205-7 Normal Function Volume Dn	6 White-Blue J209-7 U19-9	LEFT FREEWAY TOP	LEFT FLIPPER LANE	TOP RED	RIGHT BANK TOP	LEFT TROUGH	NOT USED	BOTTOM LOCK	LEFT BANK BOTTOM	BLACK-YELLOW J905-3 UPPER RIGHT FLIPPER BUTTON
Orange-Violet J205-8 Normal Function Volume Up	7 White-Violet J209-8 U19-5	RIGHT FREEWAY BOTTOM	RIGHT FLIPPER LANE	MIDDLE RED	NOT USED	CENTER TROUGH	MADE LEFT RAMP	EJECT HOLE	LEFT BANK MIDDLE	BLACK-GRAY J906-5 UPPER LEFT E.O.S. SWITCH
Orange-Grey J205-9 Normal Function Begin Test	8 White-Grey J209-9 U19-7	RIGHT FREEWAY TOP	RIGHT OUTLANE	BOTTOM RED	NOT USED	RIGHT TROUGH	NOT USED	SHOOTER	LEFT BANK TOP	BLACK-BLUE J905-5 UPPER LEFT FLIPPER BUTTON

J2XX = CPU Board OPTO = OPTO, TYPICALLY CLOSED