

# BRAM STOKER'S DRACULA (50001)

## FUSE LIST

POWER DRIVER BOARD		
F101	+50V DC General (Left Flipper)	3A, 250V, SB Not Used
F102	+50V DC General (Right Flipper)	3A, 250V, SB Not Used
F103	Solenoids #25 to #28	3A, 250V, SB
F104	Solenoids #9 to #16	3A, 250V, SB
F105	Solenoids #1 to #8	3A, 250V, SB
F106	G.I. #5 White-Violet	5A, 250V, SB
F107	G.I. #4 White-Green	5A, 250V, SB
F108	G.I. #3 White-Yellow	5A, 250V, SB
F109	G.I. #2 White-Orange	5A, 250V, SB
F110	G.I. #1 White-Brown	5A, 250V, SB
F111	Flasher Secondary	5A, 250V, SB
F112	Solenoid Secondary	7A, 250V, SB
F113	+5V Logic	5A, 250V, SB
F114	+18V Lamp Matrix	8A, 32V, N.B.
F115	+12V Switch Matrix	3/4A, 250V, FB
F116	+12V Secondary	3A, 250V, SB
Audio Board		
F501	-25V Circuit	3A, 250V, SB
F502	+25V Circuit	3A, 250V, SB
Dot Matrix Controller Board		
F601	+62V Circuit	3/8A, 250V, FB
F602	-113V & -125V Circuits	3/8A, 250V, FB
LINE FILTER		
Foreign		5A, 250V, SB
Domestic		8A, 250V, SB

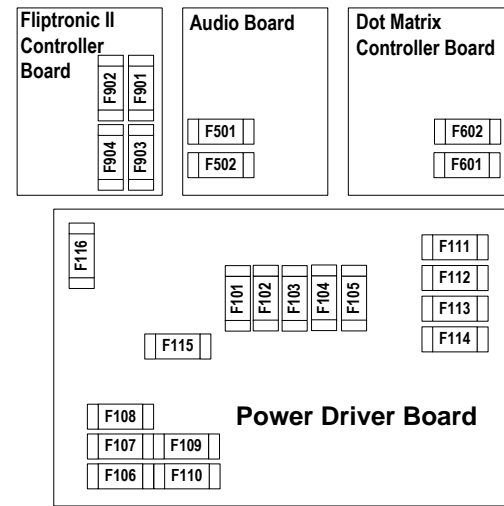

Fliptronic II Controller Board		
F901	Upper Right Flipper	3A, 250V, SB
F902	Upper Left Flipper	3A, 250V, SB
F903	Lower Right Flipper	3A, 250V, SB
F904	Lower Left Flipper	3A, 250V, SB

## SOLENOID/FLASHER TABLE

Sol No.	Function	Solenoid Type	Voltage Connections			Drive Xistor	Drive Connections			Drive Wire Color	Solenoid Part Number Flashlamp Type	
			Playfield	Backbox	Cabinet		Playfield	Insert	Cabinet		Playfield	Insert
01	SHOOTER	High Power	J107-3			Q82	J130-1			VIO-BRN	AE-23-800	
02	COFFIN POPPER	High Power	J107-3			Q80	J130-2			VIO-RED	AE-24-900	
03	CASTLE POPPER	High Power	J107-3			Q78	J130-4			VIO-ORG	AE-26-1500	
04	RIGHT RAMP DOWN	High Power	J107-3			Q76	J130-5			VIO-YEL	AE-26-1200	
05	CRYPT POPPER	High Power	J107-3			Q64	J130-6			VIO-GRN	AE-25-1500	
06	WIRE RAMP BALL POPPER	High Power	J107-3			Q66	J130-7			VIO-BLU	AE-23-800	
07	KNOCKER	High Power	J107-3			Q68	J130-8			VIO-BLK	AE-23-800	
08	SHOOTER RAMP ENTRY	High Power	J107-2			Q70	J130-9			VIO-GRY	AE-26-1500	
09	LEFT SLINGSHOT	Low Power	J107-2			Q58	J127-1			BRN-BLK	AE-26-1200	
10	RIGHT SLINGSHOT	Low Power	J107-2			Q56	J127-3			BRN-RED	AE-26-1200	
11	LEFT JET BUMPER	Low Power	J107-2			Q54	J127-4			BRN-ORG	AE-26-1200	
12	RIGHT JET BUMPER	Low Power	J107-2			Q52	J127-5			BRN-YEL	AE-26-1200	
13	BOTTOM JET BUMPER	Low Power	J107-2			Q50	J127-6			BRN-GRN	AE-26-1200	
14	RIGHT RAMP UP	Low Power	J107-2			Q48	J127-7			BRN-BLU	SM1-28-900	
15	OUTHOLE	Low Power	J107-2			Q46	J127-8			BRN-VIO	AE-27-1200	
16	TROUGH	Low Power	J107-2			Q44	J127-9			BRN-GRY	AE-26-1200	
17	T.R. CORNER / DRACULA FL	Flasher	J107-6	J106-5		Q42	J126-1	J125-1		BLK-BRN	#906(3)	#906(1)
18	JACKPOT / STOKER FLASHER	Flasher	J107-6	J106-5		Q40	J126-2	J125-2		BLK-RED	#906(1)	#906(1)
19	3-BANK / HOUSE FLASHER	Flasher	J107-6	J106-5		Q38	J126-3	J125-3		BLK-ORG	#89(1)	#906(1)
20	T.L. CORNER / MINA FLASHER	Flasher	J107-6	J106-5		Q36	J126-4	J125-4		BLK-YEL	#89(1) #906(1)	#906(1)
21	CASTLE / HELSING FLASHER	Flasher	J107-6	J106-5		Q28	J126-5	J125-5		BLU-GRN	#89(2)	#906(1)
22	L. RAMP / L. LOGO FLASHER	Flasher	J107-6	J106-5		Q30	J126-6	J125-6		BLU-BLK	#906(1)	#906(1)
23	R. RAMP / R. LOGO FLASHER	Flasher	J107-6	J106-5		Q34	J126-7	J125-7		BLU-VIO	#906(1)	#906(1)
24	ASYLUM / RENFIELD FLASHER	Flasher	J107-6	J106-5		Q32	J126-8	J125-8		BLU-GRY	#89(1)	#906(1)
25	LEFT DROP TARGET	Low Power	J107-1			Q26	*J122-1			BLU-BRN	AE-26-1200	
26	SPEAKER PANEL FLASHER	Low Power		J106		Q24		J128-2		BLU-RED		#906(3)
27	MAGNET	Low Power	J107-1			Q22	*J122-3			BLU-ORG	20-9831	
28	MAGNET'S MOTOR	Low Power	J107-6			Q20	J122-4			BLU-YEL	14-7981	

General Illumination		Voltage Connections			Drive Xistor	Drive Connections			Drive Wire	Bulb Type	
		Playfield	Backbox	Cabinet		Playfield	Backbox	Cabinet		Playfield	Backbox
01	LOWER PLAYFIELD / INSERT	G.I.	J121-1	J120-1	Q18	J121-7	J120-7		WHT-BRN	#555	#555
02	UPPER PLAYFIELD / INSERT	G.I.	J121-2	J120-2	Q10	J121-8	J120-8		WHT-ORG	#555	#555
03	CENTER PLAYFIELD / INSERT	G.I.	J121-3	J120-3	Q14	J121-9	J120-9		WHT-YEL	#555	#555
04	INSERT	G.I.		J120-5	Q16		J120-10		WHT-GRN	#555	#555
05	INSERT	G.I.		J120-6	Q12		J120-11	J119-1	WHT-VIO		#555
Flipper Circuits		Playfield Voltage Connection	Drive Transistors Power	Hold	Playfield Drive Connections	Drive Wire Colors	Hold	Coil Part No.	Coil Colors		
	LOWER LEFT FLIPPER	Flipper	J907-6, 7 (GRY-YEL)	Q3	Q9	J902-7, 9	BLU-GRY ORG-BLU	FL-15411	ORANGE		
	LOWER RIGHT FLIPPER	Flipper	J907-8, 9 (BLU-YEL)	Q4	Q11	J902-11, 13	BLU-VIO ORG-GRN	FL-15411	ORANGE		
33	UP / DOWN POST DIVERTER	Up Lt. Fl. Power	J907-2		Q1	J902-3	BLK-BLU	AE-26-1500			
34	RIGHT GATE	Up Lt. Fl. Hold	J907-1		Q5	J902-1	ORG-GRY	AE-26-1500			
35	DIS. CASTLE RELEASE POST	Up Rt. Fl. Power	J907-5		Q2	J902-6	BLK-YEL	AE-26-1500			
36	LEFT BALL GATE ACTUATOR	Up Lt. Fl. Hold	J907-4		Q7	J902-4	ORG-VIO	A-14406			

\* J122-1, 3 have tieback diodes at J122-5, 8 respectively.

## LAMP MATRIX

Column	Red ← Yellow (B+)							
	1 Yellow-Brown J133-1 Q98	2 Yellow-Red J137-2 Q97	3 Yellow-Orange J137-3 Q96	4 Yellow-Black J137-4 Q95	5 Yellow-Green J137-5 Q94	6 Yellow-Blue J137-6 Q93	7 Yellow-Violet J137-7 Q92	8 Yellow-Gray J137-8 Q91
1 Red-Brown J133-1 Q90	NOT USED	COFFIN LOCK 1	R. LANE: VIDEO "V" 31	RIGHT RETURN 41	COFFIN LAMP 1 51	LEFT SKILL 100K 61	DRACULA "C" 71	RATS MODE 81
2 Red-Black J133-2 Q89	NOT USED	COFFIN LOCK 2 22	R. LANE: VIDEO "I" 32	RIGHT DRAIN 42	COFFIN LAMP 2 52	MIDDLE SKILL 1 MILLION 62	DRACULA "L" 72	DRACULA "A" 82
3 Red-Orange J133-4 Q88	NOT USED	DRACULA "A" 23	R. LANE: VIDEO "D" 33	COFFIN MULTIBALL 43	MAGNET 53	RIGHT SKILL 100K 63	LEFT 3-BANK TOP 73	TOP-LEFT HOLE: MYSTERY 83
4 Red-Yellow J133-5 Q87	NOT USED	R. RAMP: 0.5 MILLION 24	R. LANE: VIDEO "E" 34	PLAYFIELD 2X 44	SHOOT AGAIN 54	TOP 3-LANE LEFT 64	LEFT 3-BANK MIDDLE 74	TOP-LEFT HOLE: CARRIAGE 84
5 Red-Green J133-6 Q86	NOT USED	R. RAMP: 1 MILLION 25	R. LANE: VIDEO "O" 35	CASTLE MULTIBALL 45	LOVE NEVER DIES 55	TOP 3-LANE MIDDLE 65	LEFT 3-BANK BOTTOM 75	TOP-LEFT HOLE: EXTRA BALL 85
6 Red-Blue J133-7 Q85	R. RAMP LOCK 16	R. RAMP: 2.5 MILLION 26	DRACULA "R" 36	PLAYFIELD 3X 46	COFFIN LAMP 3 56	TOP 3-LANE RIGHT 66	MIDDLE 3-BANK LEFT 76	TOP-LEFT HOLE: JACKPOT 86
7 Red-Violet J133-8 Q84	DRACULA FACE 17	R. RAMP: DOUBLE 27	LEFT DRAIN 37	MIST MULTIBALL 47	L. RAMP ENTER 57	DRACULA "U" 67	MIDDLE 3-BANK MIDDLE 77	LAUNCH BALL 87
8 Red-Grey J133-9 Q83	R. RAMP: 2 MILLION 18	R. RAMP: 1.5 MILLION 28	LEFT RETURN 38	DRACULA "D" 48	L. RAMP LOCK 58	JET INSERT 68	MIDDLE 3-BANK RIGHT 78	GAME START 88

J1XX = Power Driver Board

## SWITCH MATRIX

DEDICATED GROUNDED SWITCHES	Column	White → Green								FLIPPER GROUNDED SWITCHES
		1 Green-Brown J207-1 U20-18	2 Green-Red J207-2 U20-17	3 Green-Orange J207-3 U20-16	4 Green-Yellow J207-4 U20-15	5 Green-Black J207-5 U20-14	6 Green-Blue J207-6 U20-13	7 Green-Violet J207-7 U20-12	8 Green-Grey J207-9 U20-11	
Orange-Brown J205-1 LEFT COIN CHUTE U17-5	1 White-Brown J209-1 U18-11	NOT USED	SLAM TILT 21	UNDER SHOOTER RAMP 31	TROUGH 1-BALL 41	OPTO TOP-RIGHT LANE 51	LEFT JET 61	OPTO CASTLE POPPER 71	MAGNET LEFT 81	BLACK-GREEN J906-1 LOWER RIGHT E.O.S. SWITCH F1
Orange-Red J205-2 CENTER COIN CHUTE U17-7	2 White-Red J209-2 U18-9	NOT USED	COIN DOOR CLOSED 22	NOT USED 32	TROUGH 2-BALLS 42	OPTO MAGNET LEFT POCKET 52	RIGHT JET 62	OPTO COFFIN POPPER 72	BALL ON MAGNET 82	BLUE-VIOLET J906-2 LOWER RIGHT FLIPPER OPTO F2
Orange-Black J205-3 RIGHT COIN CHUTE U17-11	3 White-Orange J209-3 U18-5	START BUTTON 13	TICKET OPTO. 23	NOT USED 33	TROUGH 3-BALLS 43	OPTO CASTLE 1 53	BOTTOM JET 63	OPTO LEFT RAMP ENTRY 73	MAGNET RIGHT 83	BLACK-BLUE J906-3 LOWER LEFT E.O.S. SWITCH F3
Orange-Yellow J205-4 4 <sup>th</sup> COIN CHUTE U17-9	4 White-Yellow J209-4 U18-7	PLUMB BOB TILT 14	ALWAYS CLOSED 24	LAUNCH BALL 34	TROUGH 4-BALLS 44	OPTO CASTLE 2 54	LEFT SLING 64	NOT USED 74	LEFT RAMP SCORE 84	BLUE-GRAY J905-2 LOWER LEFT FLIPPER OPTO F4
Orange-Green J205-6 Normal Function Srv Crdts	5 White-Green J209-5 U19-11	LEFT DROP TARGET 15	TOP 3-LANE LEFT 25	LEFT DRAIN 35	NOT USED 45	OPTO WIRE RAMP POPPER 55	RIGHT SLING 65	NOT USED 75	LEFT RAMP DIVERTED 85	BLACK-VIOLET J906-4 UPPER RIGHT E.O.S. SWITCH F5
Orange-Blue J205-7 Normal Function Volume Dn	6 White-Blue J209-7 U19-9	LEFT DROP SCORE 16	TOP 3-LANE MIDDLE 26	LEFT RETURN 36	NOT USED 46	OPTO CRYPT POPPER 56	LEFT 3-BANK TOP 66	NOT USED 76	MIDDLE 3-BANK LEFT 86	BLACK-YELLOW J905-3 UPPER RIGHT FLIPPER OPTO F6
Orange-Violet J205-8 Normal Function Volume Up	7 White-Violet J209-8 U19-5	SHOOTER LANE 17	TOP 3-LANE RIGHT 27	RIGHT RETURN 37	NOT USED 47	OPTO CASTLE 3 57	LEFT 3-BANK MIDDLE 67	RIGHT RAMP UP 77	MIDDLE 3-BANK MIDDLE 87	BLACK-GRAY J906-5 UPPER LEFT E.O.S. SWITCH F7
Orange-Grey J205-9 Normal Function Begin Test	8 White-Grey J209-9 U19-7	NOT USED 18	RIGHT RAMP SCORE 28	RIGHT DRAIN 38	OUTHOLE 48	MYSTERY HOLE 58	LEFT 3-BANK BOTTOM 68	NOT USED 78	MIDDLE 3-BANK RIGHT 88	BLACK-BLUE J905-5 UPPER LEFT FLIPPER OPTO F8

J2XX = CPU Board = OPTO, TYPICALLY CLOSED