

WPC FUSE LIST

CAUTION!

For continued protection against risk of fire, replace only with the same type of fuse having the same ratings.

Power Driver Board					
F101	+50V DC General (Lt. Flipper)	3A, 250V, SB	F109	G.I. #2 White-Orange	5A, 250V, SB
F102	+50V DC General (Rt. Flipper)	3A, 250V, SB	F110	G.I. #1 White-Brown	5A, 250V, SB
F103	Solenoids #25 to #28	3A, 250V, SB	F111	Flasher Secondary	5A, 250V, SB
F104	Solenoids #9 to #16	3A, 250V, SB	F112	Solenoid Secondary	7A, 250V, SB
F105	Solenoids #1 to #8	3A, 250V, SB	F113	+5V Logic	5A, 250V, SB
F106	G.I. #5 White-Violet	5A, 250V, SB	F114	+18V Lamp Matrix	8A, 32V, N.B.
F107	G.I. #4 White-Green	5A, 250V, SB	F115	+12V Lamp Matrix	3/4A, 250V, FB
F108	G.I. #3 White-Yellow	5A, 250V, SB	F116	+12V Secondary	3A, 250V, SB

Audio Board	
F501	-25V 3A, 250V, SB
F502	+25V 3A, 250V, SB
Dot Matrix Controller Board	
F601	3/8A, 250V, FB +62V
F602	3/8A, 250V, FB -113V & -125V
Fliptronic II Controller Board	
F901	3A, 250V, SB Upper Right Flipper
F902	3A, 250V, SB Upper Left Flipper
F903	3A, 250V, SB Lower Right Flipper
F904	3A, 250V, SB Lower Left Flipper

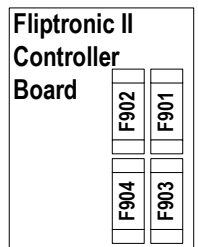
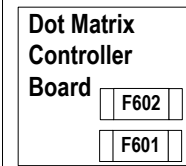
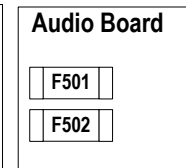
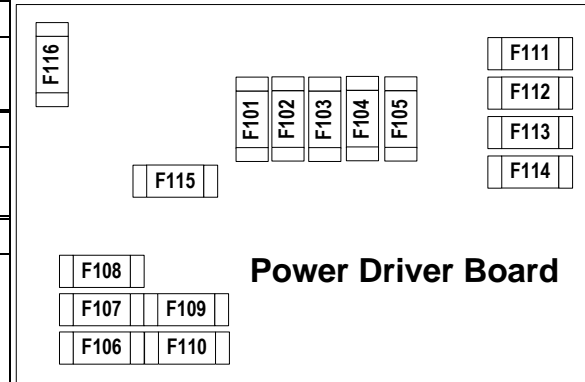

WPC FUSE LIST

CAUTION!

For continued protection against risk of fire, replace only with the same type of fuse having the same ratings.

Power Driver Board					
F101	+50V DC General (Lt. Flipper)	3A, 250V, SB	F109	G.I. #2 White-Orange	5A, 250V, SB
F102	+50V DC General (Rt. Flipper)	3A, 250V, SB	F110	G.I. #1 White-Brown	5A, 250V, SB
F103	Solenoids #25 to #28	3A, 250V, SB	F111	Flasher Secondary	5A, 250V, SB
F104	Solenoids #9 to #16	3A, 250V, SB	F112	Solenoid Secondary	7A, 250V, SB
F105	Solenoids #1 to #8	3A, 250V, SB	F113	+5V Logic	5A, 250V, SB
F106	G.I. #5 White-Violet	5A, 250V, SB	F114	+18V Lamp Matrix	8A, 32V, N.B.
F107	G.I. #4 White-Green	5A, 250V, SB	F115	+12V Lamp Matrix	3/4A, 250V, FB
F108	G.I. #3 White-Yellow	5A, 250V, SB	F116	+12V Secondary	3A, 250V, SB

Audio Board	
F501	-25V 3A, 250V, SB
F502	+25V 3A, 250V, SB
Dot Matrix Controller Board	
F601	3/8A, 250V, FB +62V
F602	3/8A, 250V, FB -113V & -125V
Fliptronic II Controller Board	
F901	3A, 250V, SB Upper Right Flipper
F902	3A, 250V, SB Upper Left Flipper
F903	3A, 250V, SB Lower Right Flipper
F904	3A, 250V, SB Lower Left Flipper

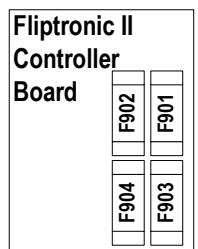
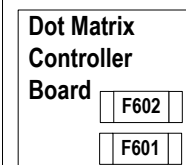
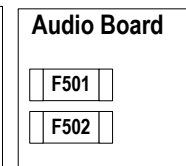
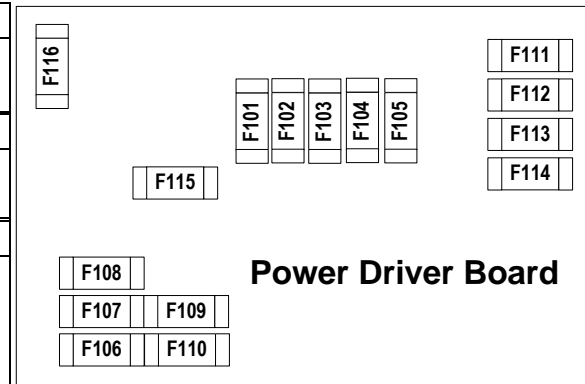

WPC FUSE LIST

CAUTION!

For continued protection against risk of fire, replace only with the same type of fuse having the same ratings.

Power Driver Board					
F101	+50V DC General (Lt. Flipper)	3A, 250V, SB	F109	G.I. #2 White-Orange	5A, 250V, SB
F102	+50V DC General (Rt. Flipper)	3A, 250V, SB	F110	G.I. #1 White-Brown	5A, 250V, SB
F103	Solenoids #25 to #28	3A, 250V, SB	F111	Flasher Secondary	5A, 250V, SB
F104	Solenoids #9 to #16	3A, 250V, SB	F112	Solenoid Secondary	7A, 250V, SB
F105	Solenoids #1 to #8	3A, 250V, SB	F113	+5V Logic	5A, 250V, SB
F106	G.I. #5 White-Violet	5A, 250V, SB	F114	+18V Lamp Matrix	8A, 32V, N.B.
F107	G.I. #4 White-Green	5A, 250V, SB	F115	+12V Lamp Matrix	3/4A, 250V, FB
F108	G.I. #3 White-Yellow	5A, 250V, SB	F116	+12V Secondary	3A, 250V, SB

Audio Board	
F501	-25V 3A, 250V, SB
F502	+25V 3A, 250V, SB
Dot Matrix Controller Board	
F601	3/8A, 250V, FB +62V
F602	3/8A, 250V, FB -113V & -125V
Fliptronic II Controller Board	
F901	3A, 250V, SB Upper Right Flipper
F902	3A, 250V, SB Upper Left Flipper
F903	3A, 250V, SB Lower Right Flipper
F904	3A, 250V, SB Lower Left Flipper

