

THE ADDAMS FAMILY (2017)

FUSE LIST

POWER DRIVER BOARD		
F101	Lower Left Flipper	3A, 250V, SB
F102	Lower Right Flipper	3A, 250V, SB
F103	Solenoids #25 to #28	3A, 250V, SB
F104	Solenoids #9 to #16	3A, 250V, SB
F105	Solenoids #1 to #8	3A, 250V, SB
F106	G.I. #2 White-Violet	5A, 250V, SB
F107	G.I. #3 White-Yellow	5A, 250V, SB
F108	G.I. #5 White-Green	5A, 250V, SB
F109	G.I. #4 White-Orange	5A, 250V, SB
F110	G.I. #1 White-Brown	5A, 250V, SB
F111	Flasher Secondary	5A, 250V, SB
F112	Solenoid Secondary	7A, 250V, SB
F113	+5V Logic	5A, 250V, SB
F114	+18V Lamp Matrix	8A, 32V, N.B.
F115	+12V Switch Matrix	3/4A, 250V, FB
F116	+12V Secondary	3A, 250V, SB
Audio Board		
F501	-25V Circuit	3A, 250V, SB
F502	+25V Circuit	3A, 250V, SB
Dot Matrix Controller Board		
F601	+80V A.C. Circuit	3/8A, 250V, FB
F602	+100V A.C. Circuit	3/8A, 250V, FB
LINE FILTER		
Foreign		4A, 250V, SB
Domestic		8A, 250V, SB

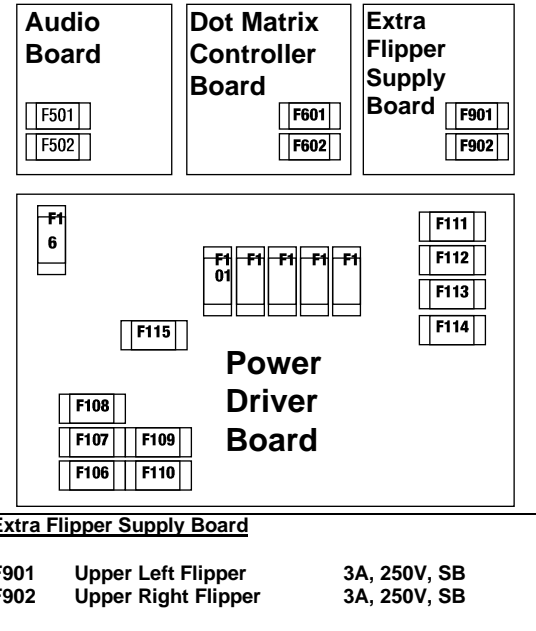

SOLENOID/FLASHER TABLE

Sol No.	Function	Solenoid Type	Voltage Connections			Drive Xistor	Drive Connections			Drive Wire Color	Solenoid Part Number Flashlamp Type	
			Playfield	Backbox	Cabinet		Playfield	Insert	Cabinet		Playfield	Insert
01	CHAIR KICKER	High Power	J107-3			Q82	J130-1			VIO-BRN	AE-23-1200	
02	THING KNOCKER	High Power	J107-3			Q80	J107-3			VIO-RED	AE-23-800	
03	RAMP DIVERTER	High Power	J107-3			Q78	J130-4			VIO-ORG	AE-26-1500	
04	BALL RELEASE	High Power	J107-3			Q76	J130-5			VIO-YEL	AE-26-1200	
05	OUTHOLE	High Power	J107-3			Q64	J130-6			VIO-GRN	AE-27-1200	
06	THING MAGNET	High Power	J107-3			Q66	J130-7			VIO-BLU	A-12158-1	
07	THING KICKOUT	High Power	J107-3			Q68	J130-8			VIO-BLK	AE-23-800	
08	LOCKUP KICKOUT	High Power	J107-3			Q70	J130-9			VIO-GRY	AE-26-1200	
09	UPPER LEFT JET	Low Power	J107-2			Q58	J127-1			BRN-BLK	AE-26-1200	
10	UPPER RIGHT JET	Low Power	J107-2			Q56	J127-3			BRN-RED	AE-26-1200	
11	CENTER LEFT JET	Low Power	J107-2			Q54	J127-4			BRN-ORG	AE-26-1200	
12	CENTER RIGHT JET	Low Power	J107-2			Q52	J127-5			BRN-YEL	AE-26-1200	
13	LOWER JET	Low Power	J107-2			Q50	J127-6			BRN-GRN	AE-26-1200	
14	LEFT SLINGSHOT	Low Power	J107-2			Q48	J127-7			BRN-BLU	AE-27-1200	
15	RIGHT SLINGSHOT	Low Power	J107-2			Q46	J127-8			BRN-VIO	AE-27-1200	
16	LEFT MAGNET *	Low Power	J107-5			Q44	J127-9			BRN-GRY	20-9247 12V	
17	TELEPHONE/UPPER RIGHT RAMP	Flasher	J107-6			Q42	J126-1	J125-1		BLK-BRN	#906	
18	TRAIN / UPPER LEFT RAMP	Flasher	J107-6			Q40	J126-2	J125-2		BLK-RED	#906	
19	LOWER RAMP / JET BUMPERS (2)	Flasher	J107-1			Q38	J126-3	J125-3		BLK-ORG	#906	
20	LEFT LIGHTNING / MINI FLIPPER	Flasher	J107-1			Q36	J126-4	J125-5		BLK-YEL	#906	
21	RIGHT LIGHTNING / SWAMP	Flasher	J107-1			Q28	J126-5	J125-6		BLU-GRN	#906	
22	THE POWER/BACKBOX CLOUD (3)	Flasher	J107-1			Q30	J126-6	J125-7		BLU-BLK	#906	
23	UPPER MAGNET *	Low Power	J107-5			Q34	J126-7	J125-8		BLU-VIO	20-9247 12V	
24	RIGHT MAGNET *	Low Power	J107-5			Q32	J126-8	J125-9		BLU-GRY	20-9247 12V	
25	THING MOTOR	Flasher	J122-5, 8			Q26	J122-1			BLU-BRN	14-7966 12V	
26	THING EJECT HOLE	Flasher	J122-6, 9			Q24	J122-2			BLU-RED	AE-30-2000	
27	BOOKCASE MOTOR	Flasher	J122-5, 8			Q22	J122-3			BLU-ORG	14-7969 12V	
28	SWAMP RELEASE	Flasher	J122-6, 9			Q20	J122-4			BLU-YEL	AE-30-2000	
General Illumination		Voltage Connections			Drive Xistor	Drive Connections			Drive Wire	Bulb Type		
		Playfield	Backbox	Cabinet		Playfield	Backbox	Cabinet		Playfield	Backbox	
01	LEFT PLAYFIELD STRING	G.I.	J120-1			Q18	J120-7			WHT-BRN	#44	
02	INSERT HOUSE STRING	G.I.		J121-2		Q10		J121-8		WHT-ORG	#555	
03	INSERT PEOPLE STRING	G.I.		J121-3		Q14		J121-9		WHT-YEL	#555	
04	NOT USED	G.I.				Q16				WHT-GRN		
05	RIGHT PLAYFIELD STRING	G.I.	J120-6		J119-3	Q12	J120-11		J119-1	WHT-VIO	#44	
Flipper Circuits		Playfield Voltage Connection		Drive Transistors		Playfield Drive Connections		Drive Wire Colors		Coil		
		Power	Hold	Power	Hold	Power	Hold	Power	Hold	Part No.	Coil Colors	
	Upper Left Flipper	Flipper	J109-5 (GRY-YEL)	Q2	Q7	BLU-GRY	ORG-BLU	FL-11753			YELLOW	
	Upper Right Flipper	Flipper	J109-7 (BLU-YEL)	Q3	Q9	BLU-VIO	ORG-GRN	FL-11630			RED	
	Lower Left Flipper	Flipper	J109-5 (GRY-YEL)	Q2	Q7	BLU-GRY	ORG-BLU	FL-15411			ORANGE	
	Lower Right Flipper	Flipper	J109-7 (BLU-YEL)	Q3	Q9	BLU-VIO	ORG-GRN	FL-15411			ORANGE	

* Magnet fuse is a 5 Amp S.B. located on the underside of the playfield.
J1XX = Power Driver Board.

LAMP MATRIX

Column	Red ← Yellow (B+) →							
	1 Yellow-Brown J137-1 Q98	2 Yellow-Red J137-2 Q97	3 Yellow-Orange J137-3 Q96	4 Yellow-Black J137-4 Q95	5 Yellow-Green J137-5 Q94	6 Yellow-Blue J137-6 Q93	7 Yellow-Violet J137-7 Q92	8 Yellow-Gray J138-9 Q91
1 Red-Brown J133-1 Q90	THING MULTIBALL 11	UPPER LEFT JET 21	G-R-E-E-D "G" 31	NOT USED 41	THING 51	LEFT SPECIAL 61	LITE ADVANCE X 71	"THING" ""-1 81
2 Red-Black J133-2 Q89	EXTRA BALL 12	UPPER RIGHT JET 22	G-R-E-E-D "R" 32	ADVANCE X 42	RAISE THE DEAD 52	LITE THING FLIPS 62	RIGHT SPECIAL 72	"THING" "T" 82
3 Red-Orange J133-4 Q88	JACKPOT 13	CENTER LEFT JET 23	G-R-E-E-D "E"-1 33	GRAVE "G" 43	LITE EXTRA BALL 53	LITE 2 BEAR KICKS 63	SHOOT AGAIN 73	"THING" "H" 83
4 Red-Yellow J133-5 Q87	GRAVE "A" 14	CENTER RIGHT JET 24	G-R-E-E-D "E"-2 34	GRAVE "R" 44	HOUSE 6 MILLION 54	ELECTRIC CHAIR YELLOW 64	VAULT GREEN 74	"THING" "I" 84
5 Red-Green J133-6 Q86	STARS 15	LOWER JET 25	G-R-E-E-D "D" 35	THE MAMUSHKA 45	QUICK MULTIBALL 55	HOUSE "7" 65	VAULT RED 75	"THING" "N" 85
6 Red-Blue J133-7 Q85	SUPER JACKPOT 16	COUSIN IT 26	5X GRAVEYARD 36	SWAMP LOCK 46	FESTER'S TUNNEL HUNT 56	HOUSE 9 MILLION 66	NOT USED 76	"THING" "G" 86
7 Red-Violet J133-8 Q84	GRAVE "V" 17	2 BEAR KICKS 27	CENTER SWAMP MILLION 37	ELECTRIC CHAIR RED 47	HOUSE SEANCE 57	GRAVEYARD AT MAX 67	THING YELLOW 77	"THING" ""-2 87
8 Red-Grey J133-9 Q83	UPPER SWAMP MILLION 18	THING FLIPS 28	LOWER SWAMP MILLION 38	GRAVE "E" 48	HIT COUSIN IT 58	HOUSE 3 MILLION 68	THING GREEN 78	CREDIT BUTTON 88

J1XX = Power Driver Board

SWITCH MATRIX

DEDICATED GROUNDED SWITCHES	Column	White → Green ←								FLIPPER GROUNDED SWITCHES
		1 Green-Brown J206-1 U20-18	2 Green-Red J206-2 U20-17	3 Green-Orange J206-3 U20-16	4 Green-Yellow J206-4 U20-15	5 Green-Black J206-5 U20-14	6 Green-Blue J206-6 U20-13	7 Green-Violet J206-7 U20-12	8 Green-Grey J206-9 U20-11	
Orange-Brown J205-1 LEFT COIN CHUTE U17-5	1 White-Brown J208-1 U18-11	NOT USED 11	SLAM TILT 21	UPPER LEFT JET 31	GRAVE "G" 41	SHOOTER LANE 51	LEFT RAMP ENTER 61	SWAMP LOCK UPPER 71	BOOKCASE OPEN 81	BLACK-GREEN J806-1 RIGHT FLIPPER E.O.S. SWITCH F1
Orange-Red J205-2 CENTER COIN CHUTE U17-7	2 White-Red J208-2 U18-9	NOT USED 12	COIN DOOR CLOSED 22	UPPER RIGHT JET 32	GRAVE "R" 42	NOT USED 52	TRAIN WRECK 62	SWAMP LOCK CENTER 72	BOOKCASE CLOSED 82	BLUE-VIOLET J805-1 RIGHT FLIPPER BUTTON F2
Orange-Black J205-3 RIGHT COIN CHUTE U17-11	3 White-Orange J208-3 U18-5	START BUTTON 13	TICKET OPTO 23	CENTER LEFT JET 33	CHAIR KICKOUT 43	BOOKCASE OPTO 1 53	THING EJECT LANE 63	SWAMP LOCK LOWER 73	NOT USED 83	BLACK-BLUE J806-3 LEFT FLIPPER E.O.S. SWITCH F3
Orange-Yellow J205-4 4 th COIN CHUTE U17-9	4 White-Yellow J208-4 U18-7	PLUMB BOB TILT 14	ALWAYS CLOSED 24	CENTER RIGHT JET 34	COUSIN IT 44	BOOKCASE OPTO 2 54	RIGHT RAMP ENTER 64	LOCKUP KICKOUT 74	THING DOWN OPTO 84	BLUE-GRAY J805-2 LEFT FLIPPER BUTTON F4
Orange-Green J205-6 Normal Function Srv Credits	5 White-Green J208-5 U19-11	LEFT TROUGH 15	RIGHT FLIPPER LANE 25	LOWER JET 35	LOWER SWAMP MILLION 45	BOOKCASE OPTO 3 55	RIGHT RAMP TOP 65	LEFT OUTLANE 75	THING UP OPTO 85	BLACK-VIOLET J806-4 UPPER RIGHT FLIPPER E.O.S. SWITCH F5
Orange-Blue J205-7 Normal Function Volume Dn	6 White-Blue J208-7 U19-9	CENTER TROUGH 16	RIGHT OUTLANE 26	LEFT SLINGSHOT 36	NOT USED 46	BOOKCASE OPTO 4 56	LEFT RAMP TOP 66	LEFT FLIPPER LANE 2 76	GRAVE "A" 86	BLACK-YELLOW J805-3 UPPER RIGHT FLIPPER BUTTON F6
Orange-Violet J205-8 Normal Function Volume Up	7 White-Violet J208-8 U19-5	RIGHT TROUGH 17	BALL SHOOTER 27	RIGHT SLINGSHOT 37	CENTER SWAMP MILLION 47	BUMPER LANE OPTO 57	UPPER RIGHT LOOP 67	THING KICKOUT 77	THING EJECT HOLE 87	BLACK-GRAY J806-5 UPPER LEFT FLIPPER E.O.S. SWITCH F7
Orange-Grey J205-9 Normal Function Begin Test	8 White-Grey J208-9 U19-7	OUTHOLE 18	NOT USED 28	UPPER LEFT LOOP 38	UPPER SWAMP MILLION 48	RIGHT RAMP EXIT 58	VAULT 68	LEFT FLIPPER LANE 1 78	NOT USED 88	BLACK-BLUE J805-5 UPPER LEFT FLIPPER BUTTON F8

J2XX = CPU Board, J8XX = Flipper Controller Board, [Yellow Box] = OPTO, TYPICALLY CLOSED