

BALLY - PARTY ZONE (2004)

FUSE LIST

POWER DRIVER BOARD		
F101	Left Flipper	2.5A, 250V, SB
F102	Right Flipper	2.5A, 250V, SB
F103	Solenoids #25 to #28	3A, 250V, SB
F104	Solenoids #9 to #16	3A, 250V, SB
F105	Solenoids #1 to #8	3A, 250V, SB
F106	G.I. #2 White-Violet	5A, 250V, SB
F107	G.I. #3 White-Yellow	5A, 250V, SB
F108	G.I. #5 White-Green	5A, 250V, SB
F109	G.I. #4 White-Orange	5A, 250V, SB
F110	G.I. #1 White-Brown	5A, 250V, SB
F111	Flasher Secondary	5A, 250V, SB
F112	Solenoid Secondary	5A, 250V, SB
F113	+5V Logic	5A, 250V, SB
F114	+18V Lamp Matrix	8A, 250V, N.B.
F115	+12V Switch Matrix	3/4A, 250V, SB
F116	+12V Secondary	3A, 250V, SB
Audio Board		
F501	-25V Circuit	3A, 250V, SB
F502	+25V Circuit	3A, 250V, SB
Dot Matrix Controller Board		
F601	+80V A.C. Circuit	3/8A, 250V, SB
F602	+100V A.C. Circuit	3/8A, 250V, SB
LINE FILTER		
Foreign		4A, 250V, SB
Domestic		8A, 250V, NB

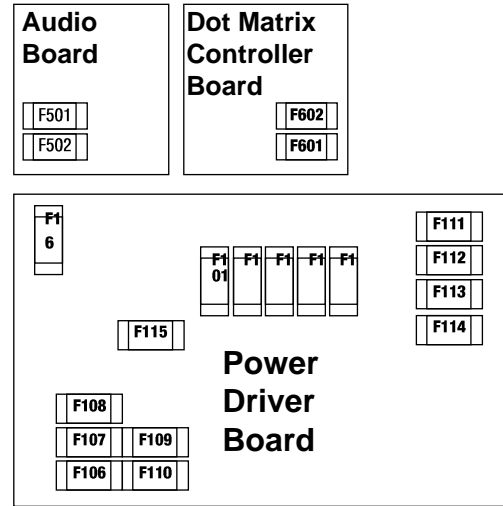

SOLENOID/FLASHER TABLE

Sol No.	Function	Solenoid Type	Voltage Connections			Drive Xistor	Drive Connections			Drive Wire Color	Solenoid Part Number Flashlamp Type	
			Playfield	Backbox	Cabinet		Playfield	Insert	Cabinet		Playfield	Insert
01	Back Ball Popper	High Power	J107-3			Q82	J130-1			VIO-BRN	AE-26-1200	
02	Right Ball Popper	High Power	J107-3			Q80	J130-2			VIO-RED	AE-26-1200	
03	D.J. Mouth	High Power	J107-3			Q78	J130-4			VIO-ORG	AE-26-1500	
04	D.J. Eject	High Power	J107-3			Q76	J130-5			VIO-YEL	AE-26-1200	
05	Dancin' Dummy	High Power	J107-3			Q64	J130-6			VIO-GRN	AE-26-1200	
06	Comic Mouth	High Power	J107-3			Q66	J130-7			VIO-BLU	AE-30-2000	
07	Kocker	High Power	J107-3			Q68	J130-8			VIO-BLK	AE-23-800	
08	Not Used	High Power				Q70				VIO-GRY		
09	Outhole	Low Power	J107-2			Q58	J127-1			BRN-BLK	AE-27-1200	
10	Ball Release	Low Power	J107-2			Q56	J127-3			BRN-RED	AE-26-1200	
11	Left Jet Bumper	Low Power	J107-2			Q54	J127-4			BRN-ORG	AE-26-1200	
12	Right Jet Bumper	Low Power	J107-2			Q52	J127-5			BRN-YEL	AE-26-1200	
13	Bottom Jet Bumper	Low Power	J107-2			Q50	J127-6			BRN-GRN	AE-26-1200	
14	Not Used	Low Power				Q48				BRN-BLU		
15	Left Slingshot	Low Power	J107-2			Q46	J127-8			BRN-VIO	AE-26-1500	
16	Right Slingshot	Low Power	J107-2			Q44	J127-9			BRN-GRY	AE-26-1500	
17	Cottage Flasher	Flasher	J107-6			Q42	J126-1			BLK-BRN	#906	
18	Rocket Flashers	Flasher	J107-6			Q40	J126-2			BLK-RED	#906	
19	Out Of Control	Flasher	J107-6			Q38	J126-3			BLK-ORG	#89	
20	Comic Flasher	Flasher	J107-6			Q36	J126-4			BLK-YEL	#906	
21	Ozone Flashers	Flasher	J107-6			Q28	J126-5			BLU-GRN	#906	
22	Right Side Flashers	Flasher	J107-6			Q30	J126-6			BLU-BLK	#89, #906	
23	Head On/Off	Special	J118-3			Q34	J126-7			BLU-VIO	AE-26-1500	
24	Head Direction	Special	J118-2			Q32	J126-8			BLU-GRY	14-7968 12V	
25	Boppers Flasher	Flasher	J107-6			Q26	J122-1			BLU-BRN	#89	
26	Left Side Flashers	Flasher	J107-6			Q24	J122-2	J123-3		BLU-RED	#89, #906	
27	Top Left Flashers	Flasher	J107-6			Q22	J122-3	J123-4		BLU-ORG	#89, #906	
28	D.J. Flasher	Flasher	J107-6			Q20	J122-4	J123-5		BLU-YEL	#906	
General Illumination		Voltage Connections			Drive Xistor	Drive Connections			Drive Wire	Bulb Type		
		Playfield	Backbox	Cabinet		Playfield	Backbox	Cabinet		Playfield	Backbox	
01	String 1	G.I.	J120-1			Q18	J120-7			WHT-BRN	#44	
02	String 2	G.I.	J120-2			Q10	J120-8			WHT-ORG	#44	
03	String 3	G.I.	J120-3			Q14	J120-9			WHT-YEL	#44	
04	String 4	G.I.		J121-5		Q16		J121-10		WHT-GRN	#555	
05	String 5	G.I.		J121-6	J119-3	Q12		J121-11	J119-1	WHT-VIO	#555	
Flipper Circuits		Playfield Voltage Connection		Cabinet Connection		Cabinet Ground				Coil Part No.	Coil Colors	
Upper Left Flipper (Not Used)		Flipper										
Upper Right Flipper (Not Used)		Flipper										
Lower Left Flipper		Flipper		J109-5 (GRY-YEL)	J109-3 (BLU-GRY)	J110-2 (ORG-GRY)				FL-11630	RED	
Lower Right Flipper		Flipper		J109-7 (BLU-YEL)	J109-4 (BLU-VIO)	J110-3 (ORG-VIO)				FL-11630	RED	

J1XX = Power Driver Board.

LAMP MATRIX

Column	Row	1	2	3	4	5	6	7	8
		Yellow-Brown J137-1 Q98	Yellow-Red J137-2 Q97	Yellow-Orange J137-3 Q96	Yellow-Black J137-4 Q95	Yellow-Green J137-5 Q94	Yellow-Blue J137-6 Q93	Yellow-Violet J137-7 Q92	Yellow-Gray J137-9 Q91
1 Red-Brown J133-1 Q90	End Zone	11	5 Million 21	Party Animals 31	Big Bang 41	Dance Contest 51	Request 61	Right Fuel 1 71	Left End Zone 81
2 Red-Black J133-2 Q89	Extra Ball	12	Boppers 1 Million 22	Party Monster 32	Fuel 1 42	Left Fuel 1 52	Time 62	Right Fuel 2 72	Right End Zone 82
3 Red-Orange J133-4 Q88	Shoot Again	13	10X Playfield 23	Party Dudes 33	Fuel 2 43	Left Fuel 2 53	Make A Request 63	Right Fuel 3 73	Comic 1 83
4 Red-Yellow J133-5 87	Ramp Eat	14	Special 24	EDM Qual. 1 34	Fuel 3 44	Left Fuel 3 54	Be Merry 64	Drink 74	Comic 2 84
5 Red-Green J133-6 Q86	2X Playfield	15	Jet Equal Million 25	EDM Qual. 2 35	Fuel 4 45	Way 55	Bonus 5X 65	Left Bopper 75	Comic 3 85
6 Red-Blue J133-7 Q85	HA 1	16	Bop B 26	EDM Qual. 3 36	Fuel 5 46	Out 56	Bonus 10X 66	Right Bopper 76	D.J. Eject 86
7 Red-Violet J133-8 Q84	HA 2	17	Bop O 27	EDM Qual. 4 37	Fuel 6 47	Of 57	Bonus 15X 67	Bottom Bopper 77	Not Used 87
8 Red-Grey J133-9 Q83	Ha 3	18	Bop P 28	EDM Qual. 5 38	Fuel 7 48	Control 58	Bonus 20X 68	Credit Button 78	Not Used 88

J1XX = Power Driver Board

SWITCH MATRIX

DEDICATED GROUNDED SWITCHES	Column	Row	1	2	3	4	5	6	7	8
			Green-Brown J206-1 U20-18	Green-Red J206-2 U20-17	Green-Orange J206-3 U20-16	Green-Yellow J206-4 U20-15	Green-Black J206-5 U20-14	Green-Blue J206-6 U20-13	Green-Violet J206-7 U20-12	Green-Grey J206-9 U20-11
Orange-Brown J205-1 LEFT COIN CHUTE U17-5	White-Brown J208-1 U18-11	Right Flipper	Slam Tilt	Back Ramp Switch	Back Ball Popper	Head Opto 1	Shooter Lane	Cottage Entrance	Way	
Orange-Red J205-2 CENTER COIN CHUTE U17-7	White-Red J208-2 U18-9	Left Flipper	Coin Door Closed	Not Used	Right Ball Popper	Head Opto 2	Lane To Top	Enter Left Ramp	Out	
Orange-Black J205-3 RIGHT COIN CHUTE U17-11	White-Orange J208-3 U18-5	Start Button	Ticket Opto	Not Used	Left Jet Bumper	Head Opto 3	Out Of Control	Left Ozone Slingshot	Of	
Orange-Yellow J205-4 4 th COIN CHUTE U17-9	White-Yellow J208-4 U18-7	Plumb Bob Tilt	Always Closed	EDM Qual. 1	Right Jet Bumper	Left Return Lane	Top Rebound	Right Ozone Slingshot	Control	
Orange-Green J205-6 Normal Function Srv Credits	White-Green J208-5 U19-11	Not Used	Not Used	EDM Qual. 2	Bottom Jet Bumper	Left Drain	Skill Shot	Outhole	2nd Cottage Switch	
Orange-Blue J205-7 Normal Function Volume Dn	White-Blue J208-7 U19-9	HA 1	Bop B	EDM Qual. 3	Not Used	End Zone Target	Request	Trough 1	Not Used	
Orange-Violet J205-8 Normal Function Volume Up	White-Violet J208-8 U19-5	HA 2	Bop O	EDM Qual. 4	Not Used	Right Return Lane	D.J. Eject	Trough 2	Not Used	
Orange-Grey J205-9 Normal Function Begin Test	White-Grey J208-9 U19-7	HA 3	Bop P	EDM Qual. 5	Not Used	Right Drain	Time	Trough 3	Not Used	

J2XX = CPU Board

Yellow = OPTO, TYPICALLY CLOSED

www.inkochito.nl