

# JUDGE DREDD (2020)

## FUSE LIST

POWER DRIVER BOARD		
F101	+50V DC General (Left Flipper)	3A, (not used)
F102	+50V DC General (Right Flipper)	3A, (not used)
F103	Solenoids #25 to #28	3A, 250V, SB
F104	Solenoids #9 to #16	3A, 250V, SB
F105	Solenoids #1 to #8	3A, 250V, SB
F106	G.I. #5 White-Violet	5A, 250V, SB
F107	G.I. #4 White-Green	5A, 250V, SB
F108	G.I. #3 White-Yellow	5A, 250V, SB
F109	G.I. #2 White-Orange	5A, 250V, SB
F110	G.I. #1 White-Brown	5A, 250V, SB
F111	Flasher Secondary	5A, 250V, SB
F112	Solenoid Secondary	7A, 250V, SB
F113	+5V Logic	5A, 250V, SB
F114	+18V Lamp Matrix	8A, 32V, NB
F115	+12V Lamp Matrix	3/4A, 250V, FB
F116	+12V Secondary	3A, 250V, SB
Audio Board		
F501	-25V	3A, 250V, SB
F502	+25V	3A, 250V, SB
Dot Matrix Controller Board		
F601	+62V	3/8A, 250V, SB
F602	-113V & -125V	3/8A, 250V, SB
LINE FILTER		
Foreign		5A, 250V, SB
Domestic		8A, 250V, SB

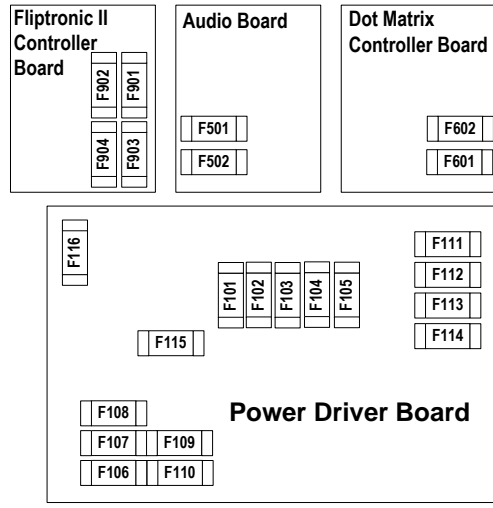

Fliptronic II Controller Board		
F901	Upper Right Flipper	3A, 250V, SB
F902	Upper Left Flipper	3A, 250V, SB
F903	Lower Right Flipper	3A, 250V, SB
F904	Lower Left Flipper	3A, 250V, SB

## SOLENOID/FLASHER TABLE

Sol No.	Function	Solenoid Type	Voltage Connections			Drive Xistor	Drive Connections			Drive Wire Color	Coil/Flashlamp Type	
			Playfield	Backbox	Cabinet		Playfield	Backbox	Cabinet		Playfield	Backbox
01	Globe Magnet	High Power	J107-3			Q82	J130-1			VIO-BRN	A-12158-1	
02	Left Popper	High Power	J107-3			Q80	J130-2			VIO-RED	AE-26-1200	
03	Right Popper	High Power	J107-3			Q78	J130-4			VIO-ORG	AE-23-800	
04	Globe Arm	High Power	J118-2			Q76	J130-5			VIO-YEL	14-7989	
05	Reset Drop Target	High Power	J107-3			Q64	J130-6			VIO-GRN	AE-24-900	
06	Globe Motor	High Power	J118-2			Q66	J130-7			VIO-BLU	14-7985	
07	Knocker	High Power	J107-3			Q68	J130-8			VIO-BLK	AE-23-800	
08	Right Shooter	Low Power	J107-3			Q70	J130-9			VIO-GRY	AE-23-800	
09	Left Shooter	Low Power	J107-2			Q58	J127-1			BRN-BLK	AE-23-800	
10	Trip Drop Target	Low Power	J107-2			Q56	J127-3			BRN-RED	AE-27-1200	
11	Diverter	Low Power	J107-2			Q54	J127-4			BRN-ORG	AE-25-1000	
12	Not Used	Low Power				Q52				BRN-YEL		
13	Trough	Low Power	J107-2			Q50	J127-6			BRN-GRN	AE-26-1500	
14	Not Used	Low Power				Q48				BRN-BLU		
15	Left Slingshot	Low Power	J107-2			Q46	J127-8			BRN-VIO	AE-27-1200	
16	Right Slingshot	Low Power	J107-2			Q44	J127-9			BRN-GRY	AE-27-1200	
17	Judge Fire Flashers	Flasher	J107-6	J106-5		Q42	J126-1	J125-1		BLK-BRN	#906	
18	Judge Fear Flashers	Flasher	J107-6	J106-5		Q40	J126-2	J125-2		BLK-RED	#906	
19	Judge Death Flashers	Flasher	J107-6	J106-5		Q38	J126-3	J125-3		BLK-ORG	#906	
20	Judge Mortis Flashers	Flasher	J107-6	J106-5		Q36	J126-4	J125-5		BLK-YEL	#906	
21	Pursuit Left Flashers	Flasher	J107-6	J106-5		Q28	J126-5	J125-6		BLU-GRN	#906 (2)	
22	Pursuit Right Flashers	Flasher	J107-6	J106-5		Q30	J126-6	J125-7		BLU-BLK	#906 (2)	
23	Blackout Flashers	Flasher	J107-6	J106-5		Q34	J126-7	J125-8		BLU-VIO	#906	
24	Cursed Earth Flashers	Flasher	J107-6			Q32	J126-8			BLU-GRY	#906 (2)	
25	Lower Left Flashers	Gen. Purpose	J107-6	J106-5		Q26	J122-1	J124-1		BLU-BRN	#89 (2)	
26	Globe Flashers	Gen. Purpose	J107-6	J106-5		Q24	J122-2	J124-2		BLU-RED	#906	
27	Right Ramp Flashers	Gen. Purpose	J107-6	J106-5		Q22	J122-3	J124-3		BLU-ORG	#89 (2)	
28	Insert Flashers	Gen. Purpose	J106-5			Q20	J124-5			BLU-YEL	#906 (3)	
General Illumination			Voltage Connections			Drive Xistor	Drive Connections			Drive Wire	Bulb Type	
			Playfield	Backbox	Cabinet		Playfield	Backbox	Cabinet		Playfield	Backbox
01	String 1	G.I.	J120-1	J121-1		Q18	J120-7	J121-7		WHT-BRN	#44	#555
02	String 2	G.I.	J120-2	J121-2		Q10	J120-8	J121-8		WHT-ORG	#555	#555
03	String 3	G.I.	J120-3	J121-3		Q14	J120-9	J121-9		WHT-YEL	#44	#555
04	String 4	G.I.	J120-5	J121-5		Q16	J120-10	J121-10		WHT-GRN	#555	#555
05	String 5	G.I.	J120-6	J121-6	J119-1	Q12	J120-11	J121-11	J119-3	WHT-VIO	#555	
Flipper Circuits		Playfield Voltage Connection			Drive Transistors		Playfield Drive Connections		Drive Wire Colors		Coil Part No.	Coil Colors
		Power	Hold		Power	Hold	Power	Hold	Power	Hold		
29	Lower Right Flipper	Power	J907-9 (BLU-YEL)		Q4		J902-13		BLU-VIO		FL-11629	BLUE
30		Hold	J907-9 (BLU-YEL)			Q11		J902-11		ORG-GRN		
31	Lower Left Flipper	Power	J907-7 (GRY-YEL)		Q3		J902-9		BLU-GRY		FL-11629	BLUE
32		Hold	J907-7 (GRY-YEL)			Q9		J902-7		ORG-BLU		
33	Upper Right Flipper	Power	J907-4 (RED-VIO)		Q2		J902-6		BLK-YEL		FL-11630	RED
34		Hold	J907-4 (RED-VIO)			Q7		J902-4		ORG-VIO		
35	Upper Left Flipper	Power	J907-1 (GRY-YEL)		Q1		J902-3		BLK-BLU		FL-11629	BLUE
36		Hold	J907-1 (GRY-YEL)			Q5		J902-1		ORG-GRY		

J1XX = Power Driver Board; J9XX = Fliptronic II Board;

## LAMP MATRIX

Column	Row	1	2	3	4	5	6	7	8							
		Yellow-Brown J137-1 Q98	Yellow-Red J137-2 Q97	Yellow-Orange J137-3 Q96	Yellow-Black J137-4 Q95	Yellow-Green J137-5 Q94	Yellow-Blue J137-6 Q93	Yellow-Violet J137-7 Q92	Yellow-Grey J137-9 Q91							
1 Red-Brown J133-1 Q90	Perp 1 (White)	11	Perp 4 (White)	21	Perp 3 (White)	31	Crime Level 4 (White)	41	Stakeout	51	Right Extra Ball	61	Drop Target "J"	71	Award Stakeout	81
2 Red-Black J133-2 Q89	Perp 1 (Red)	12	Perp 4 (Red)	22	Perp 3 (Red)	32	Crime Level 3 (Red)	42	Safecracker	52	Right Start Feature	62	Drop Target "U"	72	Blackout Jackpot	82
3 Red-Orange J133-4 Q88	Perp 1 (Yellow)	13	Perp 4 (Yellow)	23	Perp 3 (Yellow)	33	Crime Level 2 (Yellow)	43	Pursuit	53	Tank Center	63	Drop Target "D"	73	Drain Shield	83
4 Red-Yellow J133-5 Q87	Perp 1 (Green)	14	Perp 4 (Green)	24	Perp 3 (Green)	34	Crime Level 1 (Green)	44	Ultimate Challenge	54	Award Sniper	64	Drop Target "G"	74	Judge Again	84
5 Red-Green J133-6 Q86	Perp 2 (White)	15	Perp 2 (White)	25	Lock 1	35	Meltdown	45	Manhunt	55	Air Raid	65	Drop Target "E"	75	Advance Crime Level	85
6 Red-Blue J133-7 Q85	Perp 2 (Red)	16	Perp 5 (Red)	26	Lock 2	36	Impersonator	46	Blackout	56	Left Center Feature	66	Award Safecracker	76	Tank Right	86
7 Red-Violet J133-8 Q84	Perp 2 (Yellow)	17	Perp 5 (Yellow)	27	Lock 3	37	Battle Tank	47	Sniper	57	Tank Left	67	Multi-Ball Jackpot	77	Super Game	87
8 Red-Grey J133-9 Q83	Perp 2 (Green)	18	Perp 5 (Green)	28	Buy-In	38	Stop Meltdown	48	Pick A Prize	58	Mystery	68	Award Bad Impersonator	78	Start Button	88

J1XX = Power Driver Board

## SWITCH MATRIX

Column	Row	1	2	3	4	5	6	7	8	
		Green-Brown J206-1 U20-18	Green-Red J206-2 U20-17	Green-Orange J206-3 U20-16	Green-Yellow J206-4 U20-15	Green-Black J206-5 U20-14	Green-Blue J206-6 U20-13	Green-Violet J206-7 U20-12	Green-Grey J206-9 U20-11	
Orange-Brown J205-1 LEFT COIN CHUTE	White-Brown J208-1 U18-11	Left Fire Button	Slam Tilt	Buy-In (Extra Ball)	Right Ball Shooter	Left Slingshot (2)	Globe Position #1	Magnet Over Ring	Trough 1	Black-Green J906-1 Lower Right Flipper E.O.S.
Orange-Red J205-2 CENTER COIN CHUTE	White-Red J208-2 U18-9	Right Fire Button	Coin Door Closed	Not Used	Right Outlane	Right Slingshot (2)	Crane Exit	Top Right Opto	Trough 2	Black-Violet J905-1 Lower Right Flipper Opto
Orange-Black J205-3 RIGHT COIN CHUTE	White-Orange J208-3 U18-5	Start Button	Ticket Dispenser	Left Rollover	Outside Right Return	Captive Ball 2	Left Ramp To Lock	Left Popper	Trough 3	Black-Blue J906-3 Lower Left Flipper E.O.S.
Orange-Yellow J205-4 4 <sup>TH</sup> COIN CHUTE	White-Yellow J208-4 U18-7	Plumb Bob Tilt	Always Closed	Inside Right Return	Super Game	Drop Target "J"	Left Ramp Exit	Right Popper	Trough 4	Black-Gray J905-2 Lower Left Flipper Opto
Orange-Green J205-6	White-Green J208-5 U19-11	Left Shoot Lane	Top Right Post	Top Center Rollover	Not Used	Drop Target "U"	Not Used	Top Ramp Exit	Trough 5	Black-Violet J906-4 Upper Right Flipper E.O.S.
Orange-Blue J205-7	White-Blue J208-7 U19-9	Left Outlane	Captive Ball 1	Left Score Post	Not Used	Drop Target "D"	Center Ramp Exit	Right Ramp Exit	Trough 6	Black-Yellow J905-3 Upper Right Flipper Opto
Orange-Violet J205-8	White-Violet J208-8 U19-5	Left Return Lane	Mystery	Subway Enter 1	Not Used	Drop Target "G"	Left Ramp Enter	Globe Position #2	Trough 7	Black-Gray J906-5 Upper Left Flipper E.O.S.
Orange-Grey J205-9	White-Grey J208-9 U19-7	3-Bank Targets	Not Used	Subway Enter 2	Not Used	Drop Target "E"	Captive Ball 3	Not Used	Trough 8	Black-Blue J905-5 Upper Left Flipper Opto

J2XX = CPU Board; J9XX = Fliptronic II Board;

[Yellow Cell] = OPTO, TYPICALLY CLOSED

www.inkochito.nl