

BALLY – GILLIGANS ISLAND (2003)

FUSE LIST

POWER DRIVER BOARD		
F101	Left Flipper	2.5A, 250V, SB
F102	Right Flipper	2.5A, 250V, SB
F103	Solenoids #25 to #28	3A, 250V, SB
F104	Solenoids #9 to #16	3A, 250V, SB
F105	Solenoids #1 to #8	3A, 250V, SB
F106	G.I. #2 White-Violet	5A, 250V, SB
F107	G.I. #3 White-Yellow	5A, 250V, SB
F108	G.I. #5 White-Green	5A, 250V, SB
F109	G.I. #4 White-Orange	5A, 250V, SB
F110	G.I. #1 White-Brown	5A, 250V, SB
F111	Flasher Secondary	5A, 250V, SB
F112	Solenoid Secondary	5A, 250V, SB
F113	+5V Logic	5A, 250V, SB
F114	+18V Lamp Matrix	8A, 250V, N.B.
F115	+12V Switch Matrix	3/4A, 250V, SB
F116	+12V Secondary	3A, 250V, SB
Audio Board		
F501	-25V Circuit	3A, 250V, SB
F502	+25V Circuit	3A, 250V, SB
Dot Matrix Controller Board		
F601	+80V A.C. Circuit	3/8A, 250V, SB
F602	+100V A.C. Circuit	3/8A, 250V, SB
LINE FILTER		
Foreign		4A, 250V, SB
Domestic		8A, 250V, NB

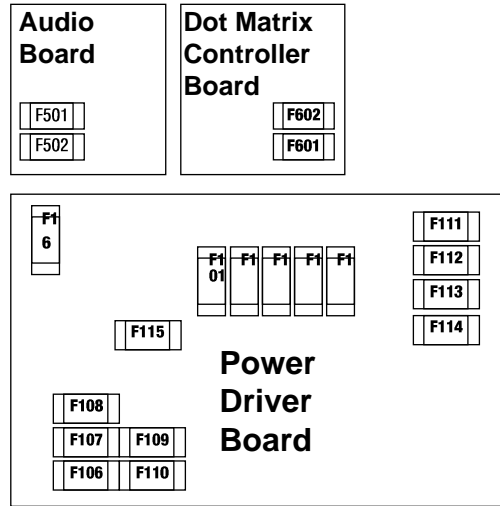

SOLENOID/FLASHER TABLE

Sol No.	Function	Solenoid Type	Voltage Connections			Drive Xistor	Drive Connections			Drive Wire Color	Solenoid Part Number Flashlamp Type	
			Playfield	Backbox	Cabinet		Playfield	Insert	Cabinet		Playfield	Insert
01	Left Lock	High Power	J107-3			Q82	J130-1			VIO-BRN	AE-23-800	
02	Island Lock	High Power	J107-3			Q80	J130-2			VIO-RED	A-14701	
03	Outhole	High Power	J107-3			Q78	J130-4			VIO-ORG	AE-26-1200	
04	Ball Popper	High Power	J107-3			Q76	J130-5			VIO-YEL	AE-26-1200	
05	Right Slingshot	High Power	J107-3			Q64	J130-6			VIO-GRN	AE-26-1500	
06	Left Slingshot	High Power	J107-3			Q66	J130-7			VIO-BLU	AE-26-1500	
07	Knocker	High Power	J107-3			Q68	J130-8			VIO-BLK	AE-23-800	
08	Kickback	High Power	J107-3			Q70	J130-9			VIO-GRY	AE-23-800	
09	Island Motor	Low Power	J107-2			Q58	J127-1			BRN-BLK	14-7964-1	
10	Trough	Low Power	J107-2			Q56	J127-3			BRN-RED	AE-26-1200	
11	Hold Lock	Low Power	J107-2			Q54	J127-4			BRN-ORG	A-14701	
12	Island Light	Low Power	J107-2			Q52	J127-5			BRN-YEL	24-8802 #906	
13	Left Jet Bumper	Low Power	J107-2			Q50	J127-6			BRN-GRN	AE-26-1200	
14	Right Jet Bumper	Low Power	J107-2			Q48	J127-7			BRN-BLU	AE-26-1200	
15	Bottom Jet Bumper	Low Power	J107-2			Q46	J127-8			BRN-VIO	AE-26-1200	
16	Top Eject	Low Power	J107-2			Q44	J127-9			BRN-GRY	AE-26-1500	
17	Head 1 Flasher	Flasher	J107-6			Q42	J125-1	J126-1		BLK-BRN	#906 #906	
18	Island Flasher	Flasher	J107-6			Q40	J125-2	J126-2		BLK-RED	#89 #906	
19	Left Bank Flasher	Flasher	J107-6			Q38	J125-3	J126-3		BLK-ORG	#89 #906	
20	Left Flipper Flasher	Flasher	J107-6			Q36	J125-5	J126-4		BLK-YEL	#89 #906	
21	Right Flipper Flasher	Flasher	J107-6			Q28	J125-6	J126-5		BLU-GRN	#89 #906	
22	Head 2 Flasher	Flasher	J107-6			Q30	J125-7	J126-6		BLU-BLK	#906 #906	
23	Ramp Up Coil	Low Power	J107-1			Q34	J126-7	Tie-Back	J126-10	BLU-VIO	AE-26-1200	
24	Ramp Down Coil	Low Power	J107-1			Q32	J126-8	Tie-Back	J126-11	BLU-GRY	SM1-26-600	
25	Right Bank Flasher	Flasher	J107-6			Q26	J122-1	J123-1		BLU-BRN	#89 #906	
26	Treasure Flasher	Flasher	J107-6			Q24	J122-2	J123-3		BLU-RED	#906 #906	
27	Title Flasher	Flasher	J107-6			Q22	J123-4			BLU-ORG	#906(2)	
28	Professor Flasher	Flasher	J107-6			Q20	J123-5			BLU-YEL	#906	
General Illumination		Voltage Connections			Drive Xistor	Drive Connections			Drive Wire	Bulb Type		
		Playfield	Backbox	Cabinet		Playfield	Backbox	Cabinet		Playfield	Backbox	
01	Left Insert String 1	G.I.	J121-1		Q18	J121-7			WHT-BRN		#555	
02	Playfield Bottom String 2	G.I.	J120-2		Q10	J120-8			WHT-ORG		#555	
03	Playfield Middle String 3	G.I.	J120-3		Q14	J120-9			WHT-YEL		#555	
04	Right Insert String 4	G.I.	J121-5		Q16	J121-10			WHT-GRN		#555	
05	Playfield Top String 5	G.I.	J120-6	J119-3	Q12	J120-11	J119-1		WHT-VIO		#555	
Flipper Circuits		Playfield Voltage Connection		Cabinet Connection		Cabinet Ground		Coil Part No.		Coil Colors		
Upper Left Flipper (Not Used)		Flipper										
Upper Right Flipper (Not Used)		Flipper										
Lower Left Flipper		Flipper		J109-5 (GRY-YEL)	J109-3 (BLU-GRY)	J110-2 (ORG-GRY)		FL-11630		RED		
Lower Right Flipper		Flipper		J109-7 (BLU-YEL)	J109-4 (BLU-VIO)	J110-3 (ORG-VIO)		FL-11630		RED		

J1XX = Power Driver Board.

LAMP MATRIX

Column	Row	1	2	3	4	5	6	7	8
		Yellow-Brown J137-1 Q98	Yellow-Red J137-2 Q97	Yellow-Orange J137-3 Q96	Yellow-Black J137-4 Q95	Yellow-Green J137-5 Q94	Yellow-Blue J137-6 Q93	Yellow-Violet J137-7 Q92	Yellow-Gray J137-9 Q91
1 Red-Brown J133-1 Q90	Outlane Bonus	Lagoon N	Left Bank Left	Item 1	Leaf 1	Turtle Top	Eject Kicker	Not Used	
2 Red-Black J133-2 Q89	Outlane 2 Million	Lagoon O	Left Bank Middle	Item 2	Leaf 2	Turtle Bottom	Eject Ramp Down 200K	Not Used	
3 Red-Orange J133-4 Q88	Outlane Gift Of Gods	Lagoon O	Left Bank Right	Item 3	Leaf 3	Turtle 2	Eject Spot	Not Used	
4 Red-Yellow J133-5 Q87	Outlane 500K	Lagoon G	Right Bank Left	Item 4	Leaf 4	Turtle 3	Eject Ramp Down 100K	Not Used	
5 Red-Green J133-6 Q86	Outlane 100K	Lagoon A	Right Bank Middle	Item 5	Leaf 5	Jungle Run Top	Not Used	Not Used	
6 Red-Blue J133-7 Q85	Left Return Lane	Lagoon L	Right Bank Right	Item 6	Treasure	Jungle Run Bottom	Rope Top	Not Used	
7 Red-Violet J133-8 Q84	Right Return Lane	Top Lock Top	Popper Ready Top	Item 7	Head Hunter	Kona Top	Rope Bottom	Not Used	
8 Red-Grey J133-9 Q83	Right Outlane	Top Lock Bottom	Popper Ready Bottom	Bonus Ball	Bananas	Kona Bottom	Not Used	Start Button	

J1XX = Power Driver Board

SWITCH MATRIX

DEDICATED GROUNDED SWITCHES	Column	Row	1	2	3	4	5	6	7	8
			Green-Brown J206-1 U20-18	Green-Red J206-2 U20-17	Green-Orange J206-3 U20-16	Green-Yellow J206-4 U20-15	Green-Black J206-5 U20-14	Green-Blue J206-6 U20-13	Green-Violet J206-7 U20-12	Green-Grey J206-9 U20-11
Orange-Brown J205-1 LEFT COIN CHUTE U17-5	White-Brown J208-1 U18-11	Right Flipper	Slam Tilt	Payoff Middle Left	Left Jet Bumper	Lagoon N	Island Entrance	Payoff Top Left	Not Used	
Orange-Red J205-2 CENTER COIN CHUTE U17-7	White-Red J208-2 U18-9	Left Flipper	Coin Door Closed	Right 10 Points	Right Jet Bumper	Lagoon O	Ramp Status	Payoff Top Right	Not Used	
Orange-Black J205-3 RIGHT COIN CHUTE U17-11	White-Orange J208-3 U18-5	Start Button	Ticket Opto	Left Lock	Bottom Jet Bumper	Lagoon O	Left Loop	Payoff Bottom Right	Top Left Loop	
Orange-Yellow J205-4 4 th COIN CHUTE U17-9	White-Yellow J208-4 U18-7	Plumb Bob Tilt	Always Closed	Not Used	Left Slingshot	Lagoon G	Right Loop	Payoff Bottom Left	Top Right Loop	
Orange-Green J205-6 Normal Function Srv Credits	White-Green J208-5 U19-11	Not Used	Left Out Lane	Left Stand Up	Right Slingshot	Lagoon A	S Turn	Lock Lane	Not Used	
Orange-Blue J205-7 Normal Function Volume Dn	White-Blue J208-7 U19-9	Trough Left	Left Return Lane	Left Bank Left	Right Bank Left	Lagoon L	Ball Popper	Wheel Lock	Not Used	
Orange-Violet J205-8 Normal Function Volume Up	White-Violet J208-8 U19-5	Trough Right	Right Return Lane	Left Bank Middle	Right Bank Middle	Ramp Stand Up	Top Eject	Wheel Opto	Not Used	
Orange-Grey J205-9 Normal Function Begin Test	White-Grey J208-9 U19-7	Outhole	Right Out Lane	Left Bank Right	Right Bank Right	Jet 10 Points	Top Right	Shooter	Not Used	

J2XX = CPU Board

Yellow = OPTO, TYPICALLY CLOSED

www.inkochito.nl