

ATTACK FROM MARS (50041)

FUSE LIST

POWER DRIVER BOARD

F101	Regulated 12V	T0.63A, 250V
F102	Solenoids #25 to #28	T4.0A, 250V
F103	Solenoids #1 to #8	T4.0A, 250V
F104	Solenoids #9 to #16	T4.0A, 250V
F105	+5V Logic	T4.0A, 250V
F106	+18V Lamp Matrix	T5.0A, 250V
F107	Flasher Secondary	T4.0A, 250V
F108	Solenoid Secondary	T6.3A, 250V
F109	Unregulated 12V	T4.0A, 250V
F110	G.I. #5 White-Violet	T4.0A, 250V
F111	G.I. #4 White-Green	T4.0A, 250V
F112	G.I. #3 White-Yellow	T4.0A, 250V
F113	G.I. #2 White-Orange	T4.0A, 250V
F114	G.I. #1 White-Brown	T4.0A, 250V
F115	+50V Flippers	T4.0A, 250V
F116	+50V Flippers	T4.0A, 250V
F117	+50V Flippers	T4.0A, 250V
F118	+50V Flippers	T4.0A, 250V

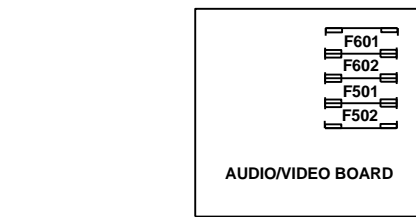

CAUTION: FOR CONTINUED PROTECTION AGAINST RISK OF FIRE, REPLACE ONLY WITH THE SAME TYPE OF FUSE HAVING THE SAME ELECTRICAL RATINGS.

AUDIO/VIDEO BOARD

F501	-25V	T2.5A, 250V
F502	+25V	T2.5A, 250V
F601	+62V	T0.25A, 250V
F602	-113V & -125V	T0.25A, 250V

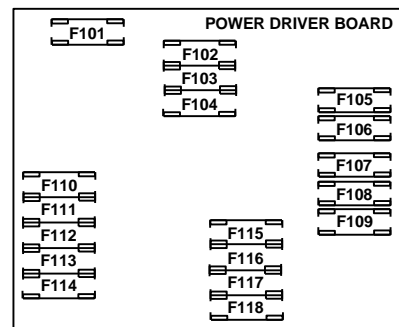

LINE FILTER

Foreign	T4.0A, 250V
Domestic	T5.0A, 250V

SOLENOID/FLASHER TABLE

Sol No.	Function	Solenoid Type	Voltage Connections			Drive Xistor	Drive Connections			Drive Wire Color	Solenoid/Flashlamp	
			Playfield	Backbox	Cabinet		Playfield	Backbox	Cabinet		Playfield	Backbox
01	AUTO PLUNGER	High Power	J133-2			Q72	J116-1			VIO-BRN	AE-23-800	
02	TROUGH EJECT	High Power	J133-2			Q68	J116-2			VIO-RED	AE-26-1500	
03	LEFT POPPER	High Power	J133-2			Q71	J116-4			VIO-ORG	AE-23-800	
04	RIGHT POPPER	High Power	J133-2			Q67	J116-5			VIO-YEL	AE-25-1000	
05	LEFT ALIEN LOW	High Power	J133-2			Q70	J116-6			VIO-GRN	AE-26-1500	
06	LEFT ALIEN HIGH	High Power	J133-2			Q66	J116-7			VIO-BLU		AE-23-800
07	KNOCKER	High Power		J133-2		Q69		J116-8		VIO-BLK	AE-26-1500	
08	RIGHT ALIEN HIGH	High Power	J133-2			Q65	J116-9			VIO-GRY	AE-26-1200	
09	LEFT SLINGSHOT	Low Power	J133-3			Q44	J113-1			BRN-BLK	AE-26-1200	
10	RIGHT SLINGSHOT	Low Power	J133-3			Q48	J113-3			BRN-RED	AE-26-1200	
11	LEFT JET	Low Power	J133-3			Q43	J113-4			BRN-ORG	AE-26-1200	
12	BOTTOM JET	Low Power	J133-3			Q47	J113-5			BRN-YEL	AE-26-1200	
13	TOP JET	Low Power	J133-3			Q42	J113-6			BRN-GRN	AE-26-1200	
14	RIGHT ALIEN LOW	Low Power	J133-3			Q46	J113-7			BRN-BLU	AE-26-1500	
15	SAUCER SHAKE	Low Power	J133-3			Q41	J113-8			BRN-VIO	AE-26-1500	
16	DROP TARGET	Low Power	J133-2			Q45	J114-9			BRN-GRY	AE-26-1200	
17	RIGHT RAMP HIGH (2)	Flasher	J133-6	J134-5		Q28	J111-1	J112-1		BLK-BRN	#906	#906
18	LEFT RAMP LOW (2)	Flasher	J133-6	J134-5		Q32	J111-2	J112-2		BLK-RED	#906	#906
19	RIGHT SIDE HIGH (2)	Flasher	J133-6	J134-5		Q27	J111-3	J112-3		BLK-ORG	#906	#906
20	RIGHT SIDE LOW	Flasher	J133-6			Q31	J111-4			BLK-YEL	#89	
21	CENTER ARROW	Flasher	J133-6			Q26	J111-5			BLU-GRN	#906	
22	JETS	Flasher	J134-6			Q30	J111-6			BLU-BLK	#89	
23	SAUCER DOME	Flasher	J134-6			Q25	J111-7			BLU-VIO	#906	
24	MOTOR BANK	Flasher	J133-6			Q29	J111-8			BLU-GRY	14-8023	
25	LEFT RAMP LEFT (2)	Gen. Purpose	J133-6	J134-5		Q16	J109-1	J107-1		BLU-BRN	#906	#906
26	LEFT RAMP RIGHT (2)	Gen. Purpose	J133-6	J134-5		Q15	J109-2	J107-3		BLU-RED	#906	#906
27	LEFT SIDE HIGH (2)	Gen. Purpose	J133-6	J134-5		Q14	J109-3	J107-4		BLU-ORG	#906	#906
28	LEFT SIDE LOW	Gen. Purpose	J133-6			Q13	J109-4			BLU-YEL	#89	
33	RIGHT GATE	High Power	J119-6,7			Q84	J120-6			YEL-VIO	A-14406	
34	LEFT GATE	Low Power	J119-6,7			Q86	J120-4			ORG-VIO	A-14406	
35	DIVERTER POWER	High Power	J119-8,9			Q81	J120-3			YEL-GRY	A-20099	
36	DIVERTER HOLD	Low Power	J119-8,9			Q83	J120-1			ORG-GRY	A-20099	
37	L.E.D CLOCK	Flasher	J140-2				J110-1			BRN-WHT	A-20670	
38	L.E.D DATA	Flasher	J140-2				J110-3			VIO-WHT	A-20670	
39	STOBE LIGHT	Flasher	J140-2					J110-4		ORG-WHT	A-20718	

General Illumination

01	BOTTOM PLAYFIELD	G.I.	J105-1	J106-1		Q5	J105-7	J106-7		WHT-BRN	#44	#555
02	MIDDLE PLAYFIELD	G.I.	J105-2			Q4	J105-8			WHT-ORG	#44, #555	
03	TOP PLAYFIELD	G.I.	J105-3			Q3	J105-9			WHT-YEL	#44, #555	
04	** TOP INSERT	G.I.		J106-5		-		J106-10		WHT-GRN		#555
05	** BOTTOM INSERT	G.I.		J106-6		-		J106-11		WHT-VIO		#555

Flipper Circuits	Power	Voltage Connection	Drive Xistors		Drive Connections	Drive Wire Colors		Coil Part No.	Coil Colors
			Power	Hold		Playfield	Power		
29	LOWER RIGHT FLIPPER	Power	J119-1 (RED-GRN)	Q90	J120-13	YEL-GRN	FL-11629	BLUE	
30		Hold	J119-1 (RED-GRN)	Q92	J120-11	ORG-GRN			
31	LOWER LEFT FLIPPER	Power	J119-4 (RED-BLU)	Q87	J120-9	YEL-BLU	FL-11629	BLUE	
32		Hold	J119-4 (RED-BLU)	Q89	J120-7	ORG-BLU			
33	RIGHT GATE	Power	J119-6 (RED-VIO)	Q84	J120-6	YEL-VIO	SEE	ABOVE	
34	LEFT GATE	Hold	J119-6 (RED-VIO)	Q86	J120-4	ORG-VIO	SEE	ABOVE	
35	DIVERTER	Power	J119-8 (RED-GRY)	Q81	J120-3	YEL-GRY	SEE	ABOVE	
36		Hold	J119-8 (RED-GRY)	Q83	J120-1	ORG-GRY			

J1xx = Power Driver Board;

** These G.I. strings do not brighten and dim, they are always ON.

LAMP MATRIX

Column	Yellow (B+) → Red							
	1 Yellow-Brown J121-1 Q96	2 Yellow-Red J121-2 Q100	3 Yellow-Orange J121-3 Q95	4 Yellow-Black J121-4 Q99	5 Yellow-Green J121-5 Q94	6 Yellow-Blue J121-6 Q98	7 Yellow-Violet J121-7 Q93	8 Yellow-Grey J121-8 Q97
1 Red-Brown J125-1 Q104	SUPER JETS	BIG-O-BEAM 1	TRACTOR BEAM 1	RIGHT LOOP ARROW	ATTACK MARS	MARTIA(N) TARGET	CAPTURE 1	SHOOT AGAIN
2 Red-Black J125-2 Q108	SUPER JACKPOT	BIG-O-BEAM 2	TRACTOR BEAM 2	CENTER RAMP ARROW	D.C. U.S.A.	MARTI(A)N TARGET	CAPTURE 2	LEFT OUTLANE
3 Red-Orange J125-4 Q103	MARTIAN ATTACK MULTIBALL	BIG-O-BEAM 3	TRACTOR BEAM 3	LEFT TOP LANE	LONDON ENGLAND	ATOMIC BLASTER 1	CAPTURE 3	LEFT RETURN
4 Red-Yellow J125-5 Q107	ANNIHIL-ATION	LEFT RAMP JACKPOT	RIGHT RAMP JACKPOT	RIGHT TOP LANE	LIGHT LOCK	ATOMIC BLASTER 2	LEFT LOOP JACKPOT	RIGHT RETURN
5 Red-Green J125-6 Q102	RETURN TO BATTLE	LEFT RAMP ARROW	RIGHT RAMP ARROW	LEFT MOTOR BANK	LOCK 1	ATOMIC BLASTER 3	LEFT LOOP ARROW	RIGHT OUTLANE
6 Red-Blue J125-7 Q106	CONQUER MARS	LOCK 2	MARTIAN ATTACK	CENTER MOTOR BANK	PISA ITALY	RIGHT LOOP JACKPOT	(M)ARTIAN TARGET	LAUNCH BUTTON
7 Red-Violet J125-8 Q101	5-WAY COMBO	LOCK 3	RULE UNIVERSE	RIGHT MOTOR BANK	BERLIN GERMANY	EXTRA BALL	M(A)RTIAN TARGET	NOT USED
8 Red-Grey J125-9 Q105	DROP TARGET	CENTER RAMP JACKPOT	STROKE OF LUCK	MAR(T)IAN TARGET	PARIS FRANCE	MART(I)AN	MA(R)TIAN TARGET	START BUTTON

J1XX = Power Driver Board

SWITCH MATRIX

DEDICATED GROUNDED SWITCHES	Column	White → Green								FLIPPER GROUNDED SWITCHES
		1 Green-Brown J206-1 U20-18	2 Green-Red J206-2 U20-17	3 Green-Orange J206-3 U20-16	4 Green-Yellow J206-4 U20-15	5 Green-Black J206-5 U20-14	6 Green-Blue J206-6 U20-13	7 Green-Violet J206-7 U20-12	8 Green-Grey J206-9 U20-11	
Orange-Brown J205-1 LEFT COIN CHUTE U17-5	1 White-Brown J208-1 U18-11	LAUNCH BUTTON	SLAM TILT	TROUGH EJECT	MARTI(A)N TARGET	LEFT SLING SHOT	LEFT RAMP ENTER	RIGHT LOOP HIGH	NOT USED	Black-Green J208-13 Lower Right Flipper E.O.S.
Orange-Red J205-2 CENTER COIN CHUTE U17-7	2 White-Red J208-2 U18-9	NOT USED	COIN DOOR CLOSED	TROUGH BALL 1	MARTIA(N) TARGET	RIGHT SLING SHOT	CENTER RAMP ENTER	RIGHT LOOP LOW	NOT USED	Blue-Violet J212-12 Lower Right Flipper Opto
Orange-Black J205-3 RIGHT COIN CHUTE U17-11	3 White-Orange J208-3 U18-5	START BUTTON	NOT USED	TROUGH BALL 2	MAR(T)IAN TARGET	LEFT JET	RIGHT RAMP ENTER	LEFT LOOP HIGH	NOT USED	Black-Blue J208-12 Lower Left Flipper E.O.S.
Orange-Yellow J205-4 4TH COIN CHUTE U17-9	4 White-Yellow J208-4 U18-7	PLUMB BOB TILT	ALWAYS CLOSED	TROUGH BALL 3	MART(I)AN TARGET	BOTTOM JET	LEFT RAMP EXIT	LEFT LOOP LOW	NOT USED	Blue-Gray J212-11 Lower Left Flipper Opto
Orange-Green J205-6 Normal Function U16-9	5 White-Green J208-5 U19-11	NOT USED	NOT USED	TROUGH BALL 4	LEFT MOTOR BANK	RIGHT JET	RIGHT RAMP EXIT	LEFT SAUCER TARGET	NOT USED	Black-Violet J208-11 Upper Right Flipper E.O.S. (NOT USED)
Orange-Blue J205-7 Normal Function U16-11	6 White-Blue J208-7 U19-9	LEFT OUTLANE	LEFT RETURN	LEFT POPPER	CENTER MOTOR BANK	(M)ARTIAN TARGET	MOTOR BANK DOWN	RIGHT SAUCER TARGET	NOT USED	Black-Yellow J212-10 Upper Right Flipper Opto
Orange-Violet J205-8 Normal Function U16-7	7 White-Violet J208-8 U19-5	RIGHT RETURN	RIGHT OUTLANE	RIGHT POPPER	RIGHT MOTOR BANK	M(A)RTIAN TARGET	MOTOR BANK UP	DROP TARGET	NOT USED	Black-Gray J208-10 Upper Left Flipper E.O.S. (NOT USED)
Orange-Grey J205-9 Normal Function U16-5	8 White-Grey J208-9 U19-7	SHOOTER LANE	NOT USED	LEFT TOP LANE	RIGHT TOP LANE	MA(R)TIAN TARGET	NOT USED	CENTER TROUGH	NOT USED	Black-Blue J212-9 Upper Left Flipper Opto

J2XX = CPU Board

Yellow = OPTO, TYPICALLY CLOSED